



Customer Substation Manual

we energies



08/05/02



Table of Contents

Section	Description
0	Preface
010.00	General
010.10	Information Required for the Review of New Customer Substations
010.20	New Customer Substation Project Information Sheet
010.30	We Energies Electrical System Information: Voltage and Fault Duties
010.40	Typical Substation One Line Reference Sheet
010.50	Schematic Index for a Typical Substation Metal Enclosed Gear with Two Line Feed
010.60	Schematic Index for a Typical Substation Metal Enclosed Gear with Two Line Feed and a Bus Tie Switch
1	Electrical Requirements
100	Service Voltage
110	Short Circuit Duty
120	Disconnecting Means for Supply Conductors
130	Unprotected Bus
140	Service Overcurrent Protection
140.10	Fuses
140.10.10	Fuse Curves
140.10.20	Fuse Mountings
140.20	Circuit Breakers
140.20.10	Relays
140.20.20	Control Supply Battery
140.30	Circuit Reclosers
140.30.10	Operating Curves
140.30.20	Reclosing Operation
150	Basic Impulse Insulation Level and Maximum Voltage Ratings
150.10	BIL Levels and Maximum Continuous Operating Voltages for Substation Equipment
160	Surge Protection
160.10	Surge Arresters
160.20	Surge Arrester Classes
170	Transformer Connections and Taps
170.10	Acceptable Transformer Connections for We Energies Systems
170.20	T-Connected Transformers
170.30	Transformer Taps
180	Station Grounding
180.10	General



Table of Contents

Section	Description
180.20	Indoor Substations
180.20.10	Basement Level Substations
180.20.20	Above Basement Level Substations
180.30	Outdoor Substations
180.40	Equipment and Structures – Indoor and Outdoor Stations
180.50	Substation Fence
180.50.10	Fence Ground Interconnected With Station Ground Grid
180.50.20	Fence Ground Isolated From Station Ground Grid
180.60	Property Fence
180.70	Outdoor Group-Operated Switches
190	Protective Grounding
190.10	General
190.20	Grounding Provisions for Specific Equipment
190.20.10	"Draw-out" Circuit Breakers
190.20.20	Stationary-Mounted Circuit Breakers
190.20.30	Oil and SF ₆ Insulated Switches
190.20.40	Power Fuses
190.30	Grounding Cable Assemblies
190.910	Grounding Facilities in Metal-Enclosed Switchgear, Entrance Bay
190.920	Power Fuse, Ground Attachment Detail
190.930	3-1/2" Ground Attachment Detail, 4-1/2" Depth and 7" Depth
190.940	12" Ground Bracket
195	Capacitors
197	Parallel Generation
2	Physical Requirements
200	Service Conductors
200.10	General
200.20	Overhead Service Conductors
200.30	Underground Service Conductors
200.30.10	Metal Enclosed or Metal Clad Switchgear Fed With Single Conductor Cable – Direct Buried or Lead Jacketed
200.30.20	Metal Enclosed or Metal Clad Switchgear Fed With Three Conductor Lead Jacketed Cable
200.30.30	Outdoor Substation on Open Framework Fed With Direct Buried or Lead Jacketed Cable
200.30.40	Special Equipment or Construction
200.30.50	Size Requirements for Openings in Basement or Foundation Walls



Table of Contents

Section	Description
200.40	Illustrations
200.40.10	Cable Support, Drilling Detail (For Lead Jacketed Cable)
200.40.20	Cable Support, Drilling Detail (For Direct Burial Cable)
200.40.30	Cable Pulling Anchor
200.40.40	Installation of Cable Pulling Anchor
210	Routes, Easements, and Space Requirements for Service Conductors
220	Metering
220.10	General
220.20	Required for Metering Above 600 Volts Only
220.20.10	Metering Instrument Transformers
220.20.20	Associated Metering Equipment
220.20.30	Metering Cubicle Unit for Metal–Clad or Metal–Enclosed Switchgear Applications
220.20.40	Metering Instrument Transformer Arrangement for Outdoor, Open–Type Substations, 34,500 Volts and Below
220.20.50	Street Light Transclosures
220.30	Loss Compensated Metering
220.40	Illustrations – Typical Arrangements
220.40.10	5kV Metering Switchgear Unit
220.40.20	15 kV Metering Switchgear Unit
220.40.30	25 kV Metering Switchgear Unit
220.40.40	26.4 kV Metering Switchgear Unit
220.40.50	34.5 kV Metering Switchgear Unit
220.40.60	Primary Metering Structure for Outdoor Open–Type Substations 15kV and Below
220.40.70	Primary Metering Structure for Outdoor Open–Type Substations 3 – Phase 4 – Wire 25kV and Below
220.40.80	Primary Metering Structure for Outdoor Open–Type Substations 3 – Phase 3 – Wire and 3 – Phase 4 – Wire 26.4kV and 34.5kV Systems
230	Clearances and Spacing
230.10	General
230.20	Operating Space for Open–Type Fuse Installations
240	Signs and Identification
240.10	General
240.20	Location
240.30	Minimum Sign Requirements for Typical Customer Substations
240.30.10	Signs for Outdoor Open–Type Substations



Table of Contents

Section	Description
240.30.20	Signs for Indoor or Outdoor Substations Consisting of Metal-Enclosed Switchgear With Loadbreak Switches and Fuses or With Draw-Out Circuit Breakers
250	Enclosures, Fences, and Surfacing – Outdoor Open Type Substations
260	Metal-Enclosed and Metal-Clad Service Entrance Switchgear
260.10	General
260.20	Doors
260.30	Windows
260.40	Detachable Panels
260.50	Screen Doors
260.60	Slide-In Barriers
260.70	Insulators
260.75	Clearances
260.80	Momentary Current Rating
260.85	Protective Grounding
260.90	Potheads and Other Cable Terminations
260.95	Accessibility to Outdoor Switchgear
270	Indoor Substations
270.10	General
270.20	Transformer Vaults
270.30	Vault Agreement
280	Interlock Systems
	General
	We Energies Required Interlocks for Specific Installations
3	Equipment Control
300	Introduction
310	Control Circuit Practices
310.10	Control Circuit Relays
310.20	Control Circuits
310.30	Bus Fault Detection
310.40	Instrument Transformer Connections
310.50	Keyed Permissive Switches
310.60	Miscellaneous Devices
320	Automatic Transfer Control for Switchgear and Circuit Breakers
320.10	Position and Transfer
320.10.10	Switch Operators and Breakers
320.10.20	Switchgear Only Requirements

**Table of Contents**

Section	Description
320.10.30	Circuit Breaker Only Requirements
320.10.30.a	Two Lines Serving a Common Load with Automatic Transfer
320.10.30.b	Two Lines Serving Separate Loads with Automatic Transfer
320.10.40	Preferred/Alternate Source Selection
320.20	Indicating Features
320.30	Sensing
330	Switchgear or Circuit Breakers with Manual Transfer
330.10	Two Lines Serving a Common Load with Manual Transfer
330.20	Two Lines Serving Separate Loads with Manual Transfer

**Preface****010.00) General**

These requirements are applicable to all customer owned substation facilities at which We Energies supply lines are terminated.

010.00.10) The requirements contained herein are exclusively those of We Energies. However, additional requirements applicable to customer substations are set forth in the Wisconsin and Michigan State Electrical Code, IEEE Standards and other codes and ordinances. We Energies should be consulted only on matters relative to its specific requirements. Customers and Consultants are advised to communicate directly with appropriate code enforcement authorities for matters which pertain to requirements of the Wisconsin and Michigan State Electrical Codes, and other local codes or ordinances.

010.00.20) The We Energies general requirements which follow have been divided into specific sections as an aid to indexing the material covered for reference purposes. The division of the first two parts has been made on the basis of whether the listed characteristic primarily involves electrical or physical design criteria. These parts are Part 1 and Part 2, respectively. Control circuit requirements for service circuit breakers and electrically operated interrupter switches are specified in Part 3.

010.00.30) The general requirements contained herein relative to supply conductor terminations, grounding provisions, service disconnecting means, overcurrent protective devices, surge protection and metering facilities are those deemed necessary to insure the reliability of the We Energies system and the safety of We Energies personnel engaged in the We Energies normal operations as the supplying utility; therefore, all customer substation installations must comply and are reviewed and inspected accordingly.

010.00.40) We Energies, in its review and inspection, may specify additional requirements relative to the equipment and general design of the substation, as We Energies in an emergency situation may be requested to act as the Customer's contractor and operate the substation equipment.

010.00.50) The Customer shall obtain the acceptance of We Energies before making any additions or modifications to any existing customer-owned substation.



Preface

010.10) Information Required for the Review of New Customer Substations

Prior to designing or ordering equipment for a customer substation, the Customer or their Contractor should request that the We Energies local office furnish **Section 010.30 “We Energies Electrical System Information: Voltage and Fault Duty”** for the proposed installation (located near the front of this manual). The Customer shall provide the following:

- The street address for the proposed installation.
- The number, type and size of the transformer(s);
- The anticipated load (present and future);
- The requested service date;
- The preferred service location;
- The type of service (switchgear line up, rack in breaker style, overhead);
- And any other pertinent data.

On completion of the substation design, the Customer shall submit quantity three (3) sets of engineering documents to the We Energies appropriate service center. ***This submittal shall occur prior to ordering any equipment.*** The prints will be reviewed for acceptance by a We Energies representative. The prints submitted for acceptance shall be details of the actual proposed installation, not typical drawings of a similar installation. These prints shall contain:

Item	Received	Require	Description
1			A one line diagram showing switches, fuses, transformers, surge arresters, interlock schemes, relaying and control schematics, etc.
2			A drawing showing the location and arrangement of the proposed installation with respect to adjacent facilities.
3			The type of equipment with reference to manufacturer and catalog number, electrical ratings, clearances between live parts and to ground, complete dimensions, etc.
4			A drawing showing the location and size of equipment foundations and ducts.
5			A drawing showing the location and provisions for metering equipment – the locations for instrument transformers, the transformer rated meter socket, the cell phone enclosure, the associated conduit runs, etc. See Section 220.
6			A drawing showing the design of the electrical ground system and the provisions for protective grounding. See Section 180.
7			The provisions for warning signs and informational signs. See Section 240.

Notes:



Preface

010.20) New Customer Substation Project Information Sheet

Today's Date	
Project Title	
Site Address	
City, State, Zip Code	
Quantity and Capacity of Transformers	
Anticipated Demand at Start Up	
Anticipated Demand at Ultimate Size	
Requested Start Up Date	
Preferred Service Location	
Customer Contact	
Phone Number	
E-Mail Address	
Contract/Design Firm	
Contact Name	
Phone Number	
Address	
City, State, Zip Code	
E-Mail	



Preface

010.30) We Energies Electrical System Information: Voltage and Fault Duty

Date:	
Customer Name and Location:	
Prepared by:	

Line 1	Circuit Number		System Description	
	3 Phase (Amps)		Line-Ground (Amps)	
	Symmetrical	Asymmetrical	Symmetrical	Asymmetrical
Present				
Future				

Line 2	Circuit Number		System Description	
	3 Phase		Line-Ground	
	Symmetrical	Asymmetrical	Symmetrical	Asymmetrical
Present				
Future				

— OR —

Line 1	Circuit Number		System Description	
	3 Phase		Line-Ground	
	Duty (Amps)	X/R	Duty (Amps)	X/R
Present				
Future				

Line 2	Circuit Number		System Description	
	3 Phase		Line-Ground	
	Duty (Amps)	X/R	Duty (Amps)	X/R
Present				
Future				

Part 1: Electrical Requirements



010.40) Schematic Index for a Typical Substation
Metal Enclosed Gear with Single Line Feed

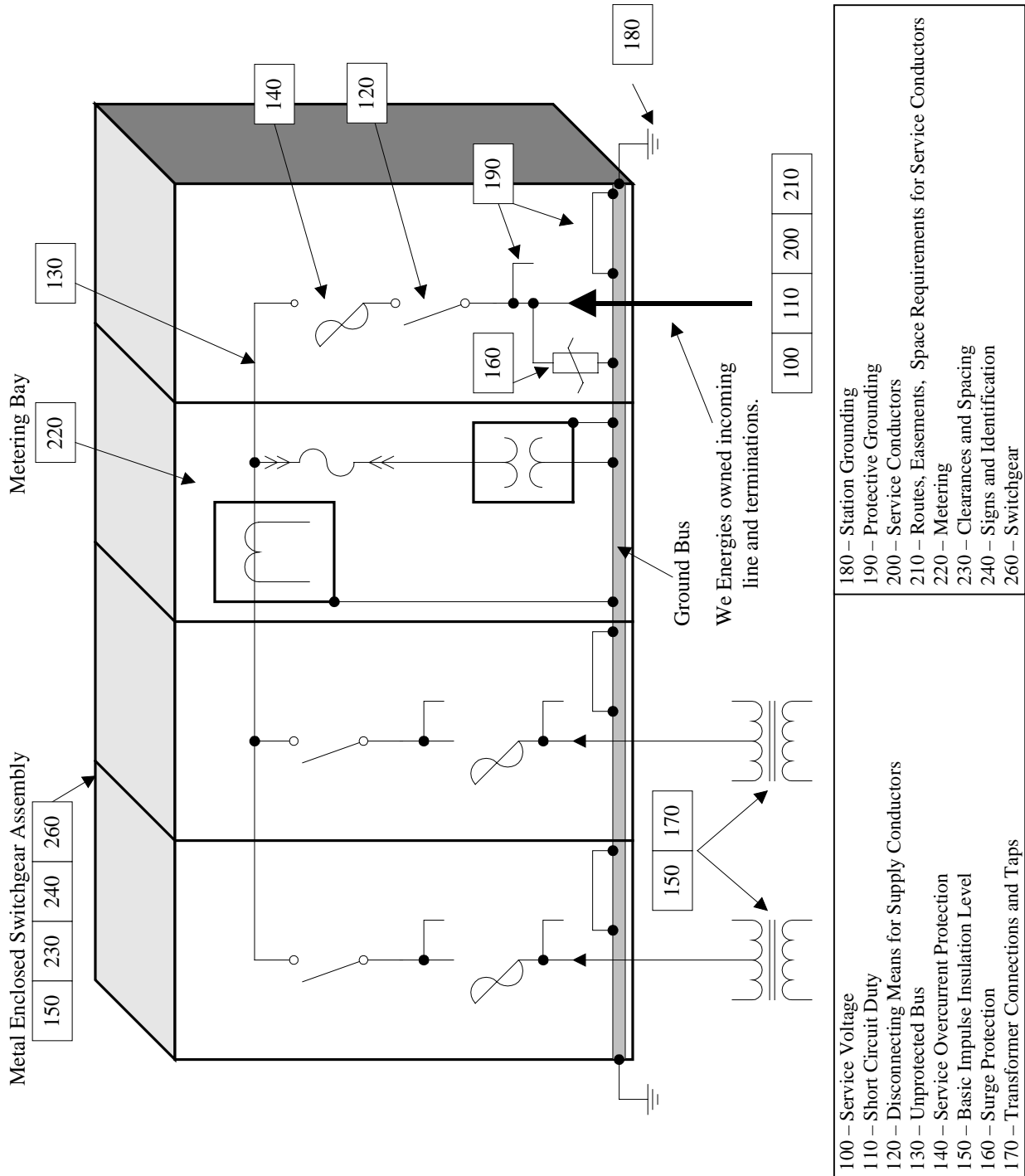

Part 1: Electrical Requirements

010.50) Schematic Index for a Typical Substation Metal Enclosed Gear with Two Line Feed

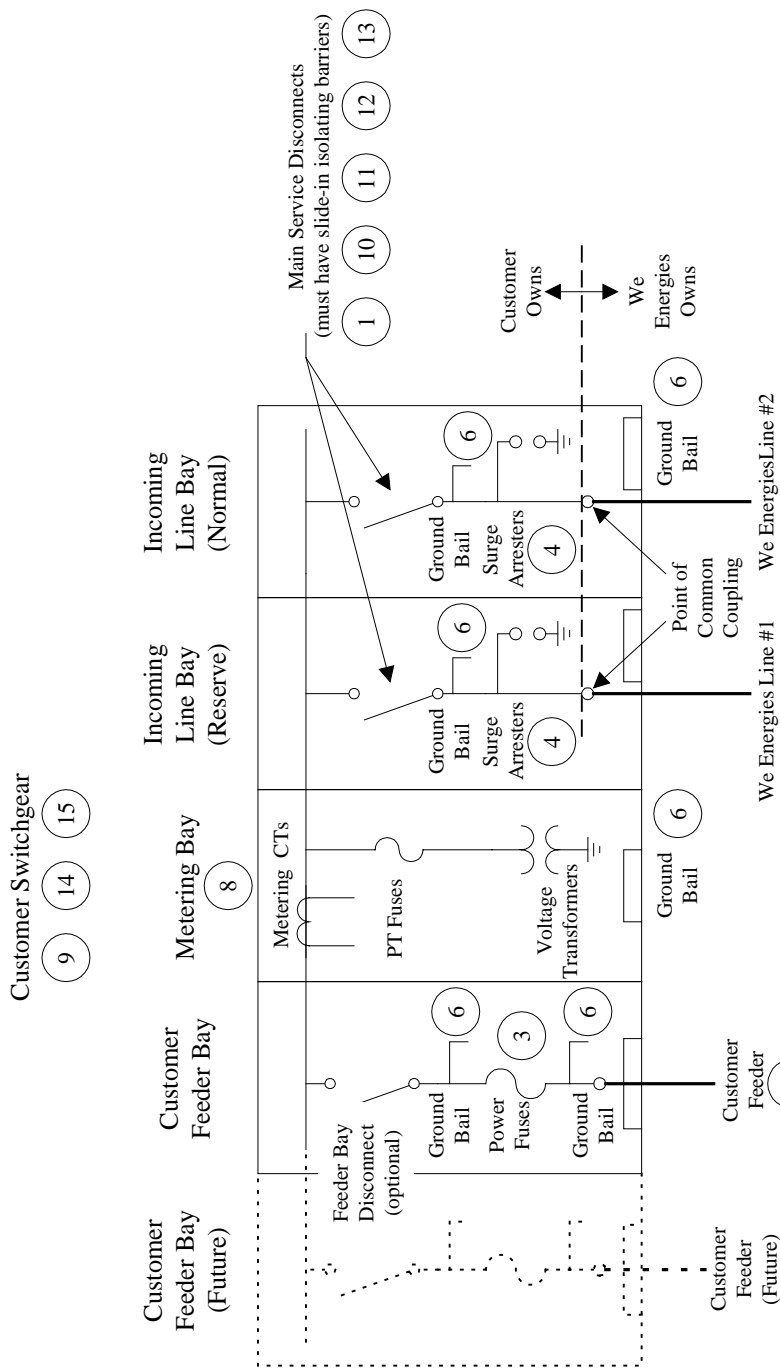

5 Station Grounding Requirements: See Section 180. All noncurrent-carrying metallic parts which may become energized or statically charged (ie: switchgear enclosures) shall be connected to the ground grid in a minimum of two locations by conductors of adequate capacity and mechanical ruggedness.

1. Main Service Disconnect	Section 120
2. Unprotected Bus	Section 130
3. Fuses, Fuse Mountings	Section 140
4. Surge Protection	Section 160
5. Station Grounding	Section 180
6. Protective Grounding	Section 190
7. Service Conductors	Section 200
8. Metering	Section 220
9. Switchgear	Section 260
10. Interlock Systems	Section 280
11. Control Circuit Practices	Section 310
12. Automatic Transfer Control	Section 320
13. Manual Transfer	Section 330
GENERAL:	
14. Clearance and Spacing	Section 230
15. Signs and Identification	Section 240

Part 1: Electrical Requirements

010.60) Schematic Index for a Typical Substation Metal Enclosed Gear with Two Line Feed and a Bus Tie Switch

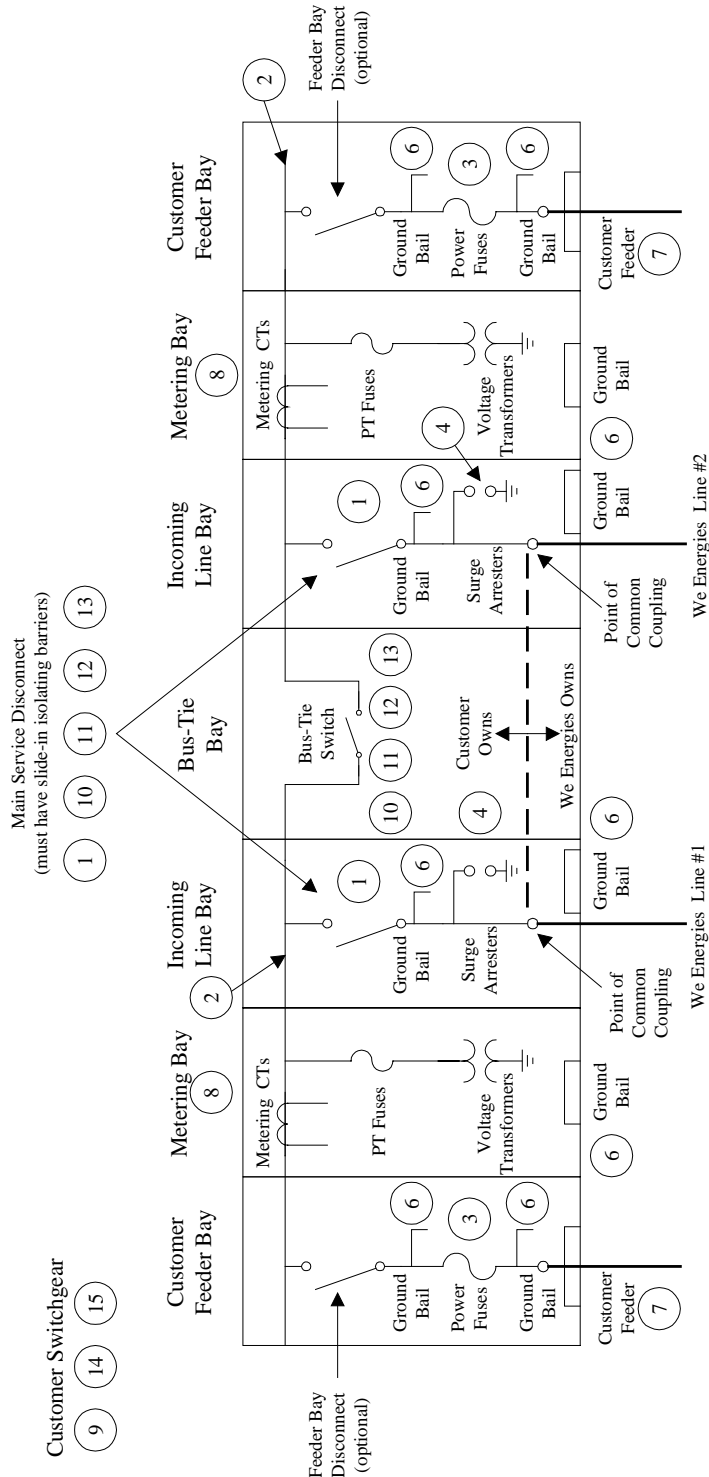

5) Station Grounding Requirements: See Section 180. All noncurrent-carrying metallic parts which may become energized or statically charged (ie: switchgear enclosures) shall be connected to the ground grid in a minimum of two locations by conductors of adequate capacity and mechanical ruggedness.

1. Main Service Disconnect	Section 120	10. Interlock Systems	Section 280
2. Unprotected Bus	Section 130	11. Control Circuit Practices	Section 310
3. Fuses, Fuse Mountings	Section 140	12. Automatic Transfer Control	Section 320
4. Surge Protection	Section 160	13. Manual Transfer	Section 330
5. Station Grounding	Section 180	GENERAL:	
6. Protective Grounding	Section 190	14. Clearance and Spacing	Section 230
7. Service Conductors	Section 200	15. Signs and Identification	Section 240
8. Metering	Section 220		



Part 1: Electrical Requirements

100) Service Voltages

We Energies will specify the service voltage. We Energies may specify the use of dual voltage equipment in some areas of its service territory to accommodate planned conversion to a different service voltage.

Part 1: Electrical Requirements

110) Short Circuit Duty

110.00.10) We Energies will provide the Customer the maximum three phase symmetrical fault current, system X/R ratio and the single phase to ground symmetrical fault current (or the maximum symmetrical and asymmetrical fault currents) for the proposed customer substation using the section 010.20 “New Customer Substation Project Information Sheet” near the front of this manual.

110.00.20) Circuit protective device(s) shall have an interrupting rating sufficient for the system voltage and the current available at the terminals of the device.

110.00.30) Circuit protective devices will be restricted in size and timing to coordinate with existing We Energies source side devices.

110.00.40) Switching and disconnecting devices shall have a fault close rating sufficient for the current available at the terminals of the device.

110.00.50) All devices shall have a momentary withstand rating sufficient for the current available at the terminals of the device.

Part 1: Electrical Requirements**120) Disconnecting Means for Supply Conductors**

120.00.10) The Customer shall provide quantity one (1) disconnect device to isolate each set of We Energies supply circuits from the Customer substation equipment.

120.00.20) The disconnect device(s) shall be located at the nearest point of connection to the We Energies owned supply conductors.

120.00.30) The disconnect device(s) shall be readily accessible. The disconnect device(s) shall be located near a door or gate providing egress from the substation. Other substation equipment shall not be located between the door or gate and the operator of the disconnect device(s).

120.00.40) Disconnect devices which are accepted by We Energies shall consist of one of the following types of equipment in 120.00.40.a through 120.00.40.d:

a) A three phase group-operated load interrupter switch. The device shall conform to the requirements of 120.00.50, 120.00.60 and 120.00.70.

b) For single phase services, a single pole load interrupter switch. The device shall conform to the requirements of 120.00.50, 120.00.60 and 120.00.70.

c) Non draw-out type circuit breakers or circuit reclosers when associated with disconnect switch(es) located on the source side of the circuit breaker or recloser. The disconnect switches shall conform to the requirements of 120.00.50.

d) Draw-out type circuit breakers.

120.00.50) The switch or disconnect shall provide a visible break of all circuit phases. The visible break shall be observable from the source side of the circuit breaker or recloser.

120.00.60) The switch shall be operated by a handle mechanism without exposing the operator to contact with live parts.

120.00.70) The operating handle shall have provisions for locking in the open and closed position. The customer shall lock the switch in the proper position, and provide a mechanism to allow We Energies personnel to operate the switch. This is typically accomplished by providing a key to the customer lock, or by providing a shackle which has an opening at either end (this allows the customer to install a lock at one end, and We Energies to install a lock at the other end).



Part 1: Electrical Requirements

120.00.80) An insulator shall be installed in the operating pipe of any switch installed on a wood pole or metal structure. This insulator shall be rated to withstand the phase to ground voltages on the system it will ultimately be served from and shall be located at an elevation of 10' to 12' above the operating handle for the switch.

Part 1: Electrical Requirements

130) Unprotected Bus

An unprotected main bus may only be installed when the following conditions are met:

130.00.10) The design of the bus and all materials used in its construction shall be in accordance with We Energies requirements.

130.00.20) All taps from the bus shall be protected by We Energies accepted overcurrent devices.

130.00.30) Insulated cable is not allowed within the unprotected zone.

130.00.40) The circuit length of unprotected strain bus shall not exceed 25 feet without We Energies acceptance.

Part 1: Electrical Requirements

140) Service Overcurrent Protection

140.10) Fuses

Fuse requirements are listed below.

140.10.10) Fuse Curves

The Customer shall provide We Energies information, including the manufacturer, type and family of time versus current curves for the proposed fuse type. We Energies will then specify the maximum fuse size that will be allowed at the particular substation location.

140.10.20) Fuse Mountings

All outdoor fuse mountings installed in Customer Substations for service protection shall be of the disconnecting type and shall be removable using a hotstick.

140.20) Circuit Breakers

Circuit breaker requirements are listed below.

140.20.10) Relays

a) We Energies will specify the type and maximum setting of overcurrent relays. The Customer shall provide We Energies certified test reports verifying relay settings and calibration.

b) The current transformers to which the overcurrent relays are connected shall be located on the supply side of the main circuit breaker.

140.20.20) Control Supply Battery

The Customer shall provide, install and maintain a stationary storage battery of sufficient capacity to ensure tripping. Capacitor tripping schemes are not acceptable.

140.30) Circuit Reclosers

Recloser requirements are listed below.

140.30.10) Operating Curves

The Customer shall provide We Energies information including manufacturer, type and operating curves. We Energies will then specify the maximum trip current or control settings.

140.30.20) Recloser Operation

The recloser must be equipped and set for single non-reclosing operation. *Automatic reclosing of Customer service protective devices is not permitted.*

Part 1: Electrical Requirements

150) Basic Impulse Insulation Levels and Maximum Continuous Operating Voltages

150.00.10) All high-voltage equipment installed by the Customer on the line side of the service overcurrent protection devices shall have a BIL rating and rated maximum continuous operating voltage not less than that stated in 150.10.

150.00.20) All service overcurrent protection devices shall have BIL ratings and rated maximum continuous operating voltages not less than that stated in 150.10.

150.00.30) For installations without main service overcurrent protective devices, the main bus insulation systems and the overcurrent protective devices connected to the main bus shall have minimum BIL ratings and rated maximum continuous operating voltages not less than that stated in 150.10 (next page).



Customer Substation Manual

08/05/02

Part 1: Electrical Requirements

150.10) BIL Levels and Maximum Continuous Operating Voltages for Substation Equipment

Nominal System Voltage (kV)	Maximum Continuous Operating Voltage (kV)	Maximum Phase-to-Ground Voltage During Faults (kV)	Equipment Rated Maximum Continuous Operating Voltage	Equipment BIL (kV)	Reduced BIL With Surge Protection (kV)	Notes
3.81Y/2.2	—	—	—	60	—	1
4.16Y/2.4	—	—	—	60	—	1
8.32Y/4.8	—	—	—	75	—	1
12.47Y/7.2	—	—	—	95	—	1
13.2Y/7.62	13.97Y/8.07	9.5	15	95	—	
13.8Y/7.97	14.52Y/8.38	10	15	95	—	
13.2	13.97	14	15	110	95	2
13.8	14.52	14.5	27	125	—	
24.94Y/14.4	26.4Y/15.24	18	27	125	—	
26.4	27.98	22	29	200	125 or 150	2
34.5Y/19.92	36.51Y/21.08	26	38	200	150	2
34.5	36.51	37	38	200	150	2
69	—	—	—	—	—	1
138	—	—	—	—	—	1

Notes:

1. By special permission only. Please contact the local We Energies office before designing for these voltages.
2. We Energies may accept the use of equipment with reduced BIL when the installation includes properly placed and appropriately rated surge arresters. We Energies shall be consulted in all cases where the installation of equipment with reduced BIL ratings is proposed.

Part 1: Electrical Requirements

160) Surge Protection

160.00.10) The Customer shall install surge arresters on all circuit phases on the line side of the main service disconnect(s). These surge arresters shall be polymer body MOV arresters and require acceptance by We Energies

160.00.20) If the Customer's distribution system is overhead and operates at the service voltage provided by We Energies (no transformation), the Customer shall install surge arresters on all circuit phases on the load side of the We Energies metering instrument transformers .

160.00.30) The application of the appropriate surge arrester class shall be determined based on the maximum fault duty quoted in section 010.30 "We Energies Electrical System Information: Voltage and Fault Duties" located near the front of this manual. Please request this form for each installation location from the local We Energies representative. This information shall be used in conjunction with sections 160.10 and 160.20 (see the next page) to determine the appropriate arrester for the each site.

160.00.40) Arrester expulsion elements shall not be used inside metal enclosed or metal clad switchgear assemblies.



Customer Substation Manual

08/05/02

Part 1: Electrical Requirements

160.10) Surge Arresters

NOMINAL CIRCUIT VOLTAGE (V)	SURGE ARRESTER			Notes
	Class	Duty Cycle Voltage Rating (kV)	MCOV Rating (kV)	
3,810Y/2,200	DISTRIBUTION	3	2.55	1
4,160Y/2,400	DISTRIBUTION	3	2.55	1
8,320Y/4,800	DISTRIBUTION	6	5.1	1
12,470/7,200	DISTRIBUTION	10	8.4	1
13,200Y/7,620	DISTRIBUTION	10	8.4	
13,800Y/7,970	DISTRIBUTION	10	8.4	
13,200	INTERMEDIATE	10	8.4	
	STATION	10	8.4	
13,800	INTERMEDIATE	15	12.7	
	STATION	15	12.7	
24,940Y/14,400	DISTRIBUTION	18	15.3	
	INTERMEDIATE	18	15.3	
26,400	INTERMEDIATE	21	17	
	STATION	21	17	
34,500	INTERMEDIATE	36	29	
	STATION	36	29	
34,500Y/19,920	INTERMEDIATE	27	22	
	STATION	27	22	
69,000				1
138,000				1

Note 1: By special permission only. Please contact the local We Energies office before designing for these voltages.

160.20) Surge Arrester Class

CLASS	PHASE TO GROUND SYMMETRICAL FAULT CURRENT (AMPERES)
Distribution	10,000 or less
Intermediate	20,000 or less
Station	>20,000

Part 1: Electrical Requirements



170) Transformer Connections and Taps

170.10) Acceptable Transformer Connections for We Energies Systems.

Row	Nominal System Voltage	Acceptable Transformer Connections			
		3 Wire Secondary		4 Wire Secondary	
		Primary	Secondary	Primary	Secondary
1	*3,810/2,200V 4 Wire *4,160/2,400V 4 Wire *8,320/4,800V 4 Wire *12,470/7,200V 4 Wire 13,200/7,620V 4 Wire 13,800/7,970V 4 Wire 13,200V 3 Wire 26,400V 3 Wire 34,500V 3 Wire	Δ	Δ	Δ	GND Y
	Δ	Y			
	Y	Δ			
2	13,800V 3 Wire <i>See 170.10.a.</i>	Δ	Y	Δ	GND Y
3	24,940/14,400V 4 Wire 34,500/19,920V 4 Wire <i>See 170.10.b.</i>	GND Y	Y	GND Y	GND Y
		Triplex Core Only		Triplex Core Only	
4	24,940/14,400V 4 Wire 34,500/19,920V 4 Wire <i>Transformer must be 3000kVA or larger, or be protected as described in 170.10.b.3.</i>	Δ	Δ	Δ	GND Y
		Δ	Y		
		Y	Δ		
5	24,940/14,400V 4 Wire 34,500/19,920V 4 Wire <i>Transformer must be protected as described in 170.10.b.3.</i>	GND Y	Y	GND Y	GND Y
6	*69,000V 3 Wire				
7	*138,000 V 3 Wire				

*By special permission only. Please contact the local We Energies office before designing for these systems.

Table 170.10 is continued on the next page.

Part 1: Electrical Requirements

170.10) (continued)

a) On the 13,800V 3 wire system, it is recommended that the Customer install three single phase transformers connected phase-to-phase. When the We Energies distribution system is converted to 24,940/14,400V 4 wire operation, the transformers may be reconnected in a grounded-wye configuration (taking advantage of the high voltage taps as well).

b) On the 24,940Y/14,400 volt and 34,500Y/19,920 volt systems, transformer installations shall have grounded-wye primary winding connections, and three phase triplex core and coil design with grounded-wye or ungrounded-wye secondary winding connections. These restrictions are designed to avoid ferroresonant conditions and eliminate tank heating phenomena under all abnormal system operating conditions.

b.1) Exception 1: When banking single phase transformers connected in a grounded-wye to grounded-wye configuration or grounded-wye to ungrounded-wye configuration.

b.2) Exception 2: When the transformer rating is 3000kVA or more, transformer connections in Row 4 of 170.10 are acceptable.

b.3) Exception 3: When transformer(s) are protected with devices which sense the loss of source voltage by measuring voltage magnitude and phase angle, and will simultaneously disconnect all phases of the high voltage supply to the transformer(s) in the event of a loss of phase condition. *Contact the local We Energies representative for acceptability before proceeding with this exception.*

b.4) Exception 4: Where a customer presently owns and operates a system and is adding transformation, the transformer connections on the existing equipment are acceptable for the new equipment (providing the connections are listed in Row 4 of 170.10).

170.20) T-Connected Transformers

T-connected transformers shall not be utilized by the Customer at the We Energies supply voltage.

170.30) Transformer Taps

Each transformer shall have five full capacity primary taps with one at nominal system voltage, and two taps at 2 1/2% above, and two taps at 2 1/2% below nominal system voltage. *Customers installing transformers supplied by We Energies 13,800 volt and 26,400 volt distribution system shall contact We Energies for specific tap requirements prior to ordering the equipment.*

Part 1: Electrical Requirements



180) Station Grounding

180.10) General

180.10.10) All substation grounding shall comply with the Wisconsin and Michigan State Electrical Codes and applicable local ordinances. The goal of a substation grounding system design is for the preservation of human life and the protection of equipment through the control of local potential.

180.10.20) This defines the minimum Company requirements for a grounding system; however it is not a design guide. The customer is responsible for the complete design. The following requirements are regarded by We Energies as minimum standards that must be met before We Energies personnel will enter and operate a customer substation, but do not in themselves guarantee that the design is adequate. A Company representative may add to the requirements and recommendations according to site conditions.

180.10.30) The size of the ground conductor shall be appropriate for the magnitude of the available fault current, the operating time of protective devices, and for sufficient mechanical ruggedness. The minimum conductor size for the ground grid and connections to the grid, ground rod and equipment cases shall be #1/0 copper.

180.20) Indoor Substations

180.20.10) Basement Level Substations

a) A 1/4" x 1-1/2" aluminum bar or equivalent copper bar shall be installed along all inside walls of the vault to form a closed loop. In damp areas copper bar shall be utilized.

b) Five-eighths (5/8) inch diameter copperweld ground rods shall be driven at all vault corners and approximately equally spaced along vault walls. Single 8-foot long rods at each rod location are adequate. Install as many ground rods as space permits, maintaining 6-foot typical separation between rods. Do not locate ground rods under doorways or in any other position where they will be hazardous to people walking in the vault. All ground rods are to be connected to the ground bus.

180.20.20) Above Basement Level

a) A 1/4" x 1-1/2" aluminum bar or equivalent copper bar shall be installed along all inside walls to form a closed loop. In damp areas copper bar should be utilized.

b) The ground bar referred to in 180.20.20.a) shall be bonded to building steel in at least four places. The frames of all major equipment shall be bonded to building steel.

Part 1: Electrical Requirements

180.30) Outdoor Substations

180.30.10) A grid is required under the entire area substation, consisting of bare–stranded copper cable buried 18 to 24 inches below the soil rough grade . The grid conductors shall be placed 15 feet apart or less depending on soil resistivity. In areas in which We Energies suspects high–resistivity soil, such a quarry, step and touch potential calculations shall be provided with the approval drawings per IEEE 80. A 4–ft by 2 ft grounding mesh is an acceptable supplement to the grid in the absence of these calculations. When required, the supplemental mesh must be installed on top of the rough grade, just under the crushed stone layer. Within the grid, cables connecting ground rods should be laid in parallel lines and uniformly spaced. They should be located, where practical, along rows of structures or equipment to facilitate the making of ground connections. These rows are to be interconnected at various points including the peripheral cable to form a grid. Interconnecting conductor size should not be less than that of the ground bus or grid.

180.30.20) Five–eighths (5/8) inch diameter copperweld ground rods shall be driven to a depth of 8 feet or more at all ground grid corners and approximately equally spaced along the grid perimeter. All ground rods are to be connected to the grid conductors.

180.30.30) A layer of gravel or crushed stone (minimum 6 inches in depth) shall be placed over the entire grid to establish the finished grade.

180.30.40) A buried ground conductor shall encircle all switchgear and transformers within 18 inches of the edge of the equipment enclosure, at a burial depth of at least 18 inches but less than 24 inches.

180.40) Equipment and Structures – Indoor and Outdoor Stations

All noncurrent–carrying metallic parts which might accidentally become energized or statically charged (such as switchgear enclosures, metal structures, building steel, transformer tanks, metal railings, housings, and guards, oil circuit breaker tanks and circuit neutrals) shall be connected to the grid or ground bus in a minimum of two locations by conductors of adequate capacity and mechanical ruggedness. The grid or ground bus should also be connected to any metallic water pipe, metallic drain or sewer pipe located in the station area. Connection shall be made at two points on the pipe at least 20 feet apart and shall consist of a conductor not less than the size of the ground bus.

180.50) Substation Fences

The metal fence surrounding an outdoor open–type substation shall be grounded in accordance with all applicable electrical codes. Of primary concern in the design of a fence grounding system is the reduction of potentials which could prove hazardous to persons within the fence enclosure or approaching from outside.

Part 1: Electrical Requirements

180.50.10) Fence Ground Interconnected With Station Ground Grid

- a) Consideration shall be given to interconnecting the station ground grid with the fence grounds at frequent intervals.
- b) The station ground grid shall be extended 2 feet beyond the substation fence. All corner and gate posts, as well as fence posts shall be connected to the grid.
- c) All metallic fence parts that might accidentally become energized or statically charged must be metallically connected together. At each entrance gate a buried ground conductor loop connected at each end to the perimeter fence ground conductor shall be placed so as to form a rectangle which encompasses an area extending at least 18 inches beyond the gate swing.

180.50.20) Fence Ground Isolated From Station Ground Grid

- a) If the Customer elects to isolate the fence ground system from the station ground grid, a potential difference may be present between the station equipment and the fence during fault conditions.
- b) Under this condition, a minimum separation of 6 feet shall be maintained between the fence and the nearest station ground conductor, grounded equipment, or structure.

180.60) Property Fence

180.60.10) These requirements are in addition to grounding requirements for substation fences (Item F above). Where a metallic property fence is attached to, or passes within 6 feet of a substation fence, it becomes an extension of the substation fence and must be treated accordingly.

180.60.20) Metal property fences installed on the Customer's property shall be grounded to ground rods installed one foot inside the fence at corner posts, gate posts, and at posts on each side of an overhead transmission or distribution line crossing. No connection with the substation ground system is necessary where a minimum separation of 6 feet is maintained between the substation fence and metallic property fence. A buried conductor connecting gateposts is recommended. Fence isolation sections may be utilized to electrically isolate extended sections of property fence from the substation.

Part 1: Electrical Requirements

180.70) Outdoor Group–Operated Switches

In outdoor stations utilizing load break switches mounted on wood poles or metal structure, a three–foot by four–foot metallic grating shall be installed on the surface where a person stands when operating the switch. This section of grating shall be connected to the ground grid and the switch operating linkage as close as is practical to the handle. A minimum of #1/0 Cu conductor shall be used for this connection.

Part 1: Electrical Requirements

190) Protective Grounding

190.10) General

The following requirements shall be used as a guide for determining when and where provisions are needed for the attachment of temporary grounds.

190.10.10) Protection of personnel and property is the primary reason for the attachment of temporary grounds. Hazardous potential differences can exist between apparently de-energized electrical conductors or current-carrying parts of equipment and some other point. These potential differences may exist if the conductor is either accidentally energized or becomes charged because of its proximity to other energized conductors. Proper grounding and bonding will effectively eliminate such hazards.

190.10.20) Wisconsin and Michigan's State Electrical Codes and company operating practices dictate that de-energized conductors and other current-carrying equipment parts shall be grounded during the time construction or maintenance work is being done on them. Such grounding is generally accomplished by connecting a temporary ground cable assembly between the conductor and some grounded point. Under certain conditions, special provisions for the attachment to equipment such as grounding switches may be required where the use of individual ground cables would be impractical or hazardous.

190.10.30) The customer shall install "adequate grounding provisions" in each customer substation.

190.10.40) The Company requirements which follow do not cover every situation where grounds might be needed. However, by using the specific requirements included herein as a guide and with an understanding of the hazards involved if grounds are not applied, "adequate provisions" can be made at locations not specifically covered. Each potential source shall be isolated by a visible open from the work area. In addition, safety grounds shall be installed between the visible open and the work area. This document is intended to describe the equipment to meet those criteria.

190.10.50) In some substations grounds can be attached directly to the equipment or conductors. However, because of the limitation in ground clamp range and physical clearances required for safe installation of such clamps, special provisions (ground attachment details) must be made in certain cases for the attachment of ground cable assemblies. Such special provisions (ground attachment details) are also required for bus conductors of special shapes, such as rectangular bar, angle, channel, etc., and at certain locations to make the application of grounds more convenient.

190.10.60) All grounding provisions installed by the customer shall be located so as to render them accessible for safe and convenient application of ground cable assemblies.

Part 1: Electrical Requirements

190.10.70) The Customer shall provide and install Company–approved grounding provisions for each incoming line (overhead service conductor or underground service cable). Refer to drawing 190.910.

190.10.80) Unless otherwise specified or permitted, such grounding provisions shall consist of a ground attachment detail permanently attached to each incoming line conductor at a conveniently accessible point on the line side of the Customer's main disconnect and ground bracket(s) located within the incoming line section and permanently connected to the station ground bus.

190.10.90) Refer to drawings 190.920, 190.930, and 190.940 for material specifications on the ground details and brackets.

190.20) Grounding Provisions for Specific Equipment

Applications for which basic requirements for line grounding provisions differ from those indicated above are outlined in the following paragraphs:

190.20.10) "Draw–out" Circuit Breakers

a) When "draw–out" circuit breakers are used for service switching and overcurrent protection at customer substations, the customer shall provide a three–pole ground/test device.

b) The ground test device is racked into a compartment in place of the circuit breaker, providing access to the completely insulated switchgear bus conductors for line grounding, bus grounding, low–voltage phase identification, and live–line phasing. Ground cable assemblies and ground brackets are used to complete the connections between the line or bus conductors and the substation ground system. An additional ground/test device may be required in some configurations .

190.20.20) Stationary–Mounted Circuit Breakers

In all customer substations using stationary–mounted circuit breakers for service protection, the Customer shall install ground attachment facilities on both line and load side of the breaker. These facilities can generally be installed on the breaker bushings or isolation disconnect switches. Ground brackets connected to the station ground bus are required for each set of attachment facilities.

Part 1: Electrical Requirements

190.20.30) Oil and SF₆ Insulated Switches

190.20.30.a) Oil switches utilized as the customers' service disconnect shall have incoming cable terminations in air-filled compartments. Isolating means shall be provided between the cable terminations and the switch tank bushings. The customer shall provide and install a ground attachment detail at each cable termination. Ground brackets connected to the station ground bus shall be provided for each set of ground attachment facilities.

190.20.30.b) An alternate method may be employed through the use of insulated connectors and bushings. These must have the capability for phase testing, Hi-Potential and fault locate testing, testing for energized/de-energized condition, providing a visible circuit open point, and line grounding.

190.20.40) Power Fuses

The customer equipment shall accommodate grounding on both supply and load side of power fuses which cannot be replaced by means of a switch stick (due to weight, lack of accessibility, or the style of the fuse mount). These accommodations shall consist of ground attachment details installed on the supply side and load side terminals of each fuse mounting. Further, the fuse bay shall contain ground brackets totaling a minimum of 18". The ground brackets shall be connected to the station ground bus. These details are to accommodate safe and expeditious fuse replacement.

Exception: Supply side grounding details are not required if the equipment has slide in isolating barriers for the fuses (or switch – if located in the same compartment).

190.30) Grounding Cable Assemblies

190.30.10) The customer shall provide all necessary grounding cables.

190.30.20) Ground cable assemblies shall be rated for their intended application.

In cases where the Company's standard ground cable assemblies are of inadequate length, special clamping devices are required, the substation is not directly accessible from outside, or other unique circumstances prevail, the Customer shall provide special ground cable assemblies to be used only at the applicable station.

190.30.30) Where additional grounding provisions are installed beyond those specifically required by the Company, and/or where the Company required grounding provisions also include facilities for station bus or equipment grounding, as in the case of ground-test devices (see **190.20.10.**), the Customer shall provide at least one set consisting of three ground cable assemblies. Such cable assemblies shall be of adequate size and sufficient length as required for the specific application.



Part 1: Electrical Requirements

190.30.40) When required to provide ground cable assemblies, the Customer shall also provide suitable storage facilities for such devices. When not in use, ground cable assemblies should be stored appropriately for accessibility and protection from the elements.

Part 1: Electrical Requirements

190.910

Grounding Facilities in Metal-Enclosed Switchgear Service Conductor Entrance Bays

ITEM	DESCRIPTION
1.	SWITCHGEAR GROUND BUS
2.	12-INCH GROUND BRACKET (SEE 190.940)
3.	3 1/2" GROUND ATTACHMENT DETAIL (SEE 190.930)
4.	SLIDE-IN ISOLATING BARRIER: REQUIRED FOR SUBSTATIONS SUPPLIED BY TWO OR MORE LINES.
5.	HINGED DOOR PER 260.20
6.	HINGED SCREEN DOOR(S) PER 260.50

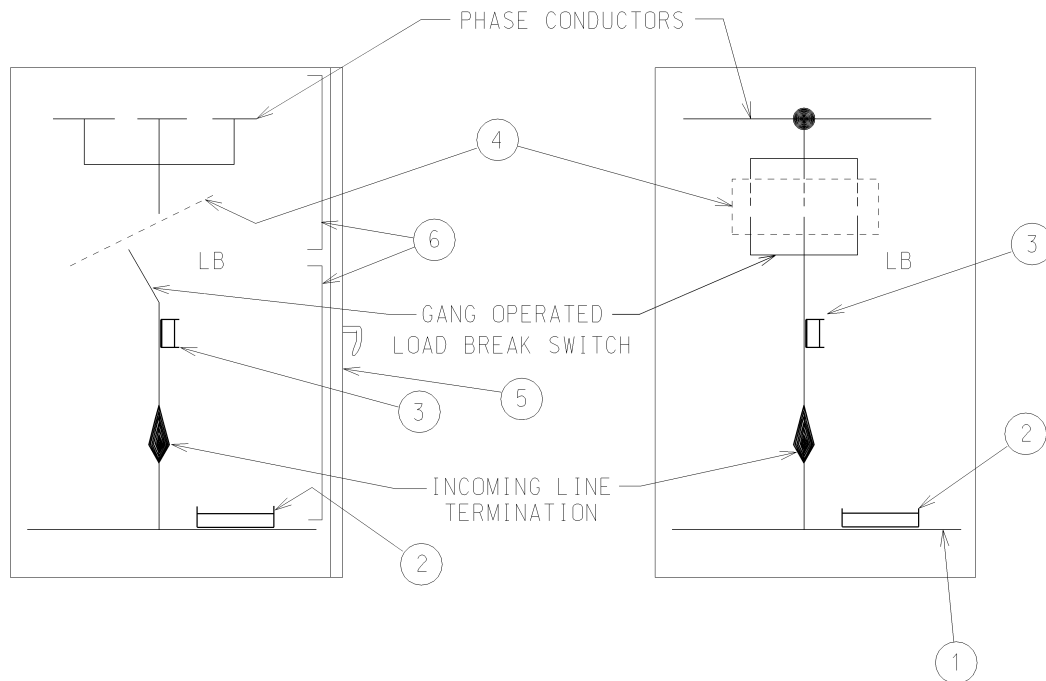

CGS File #91443F5

Part 1: Electrical Requirements

190.920

Power Fuse Ground Attachment Detail

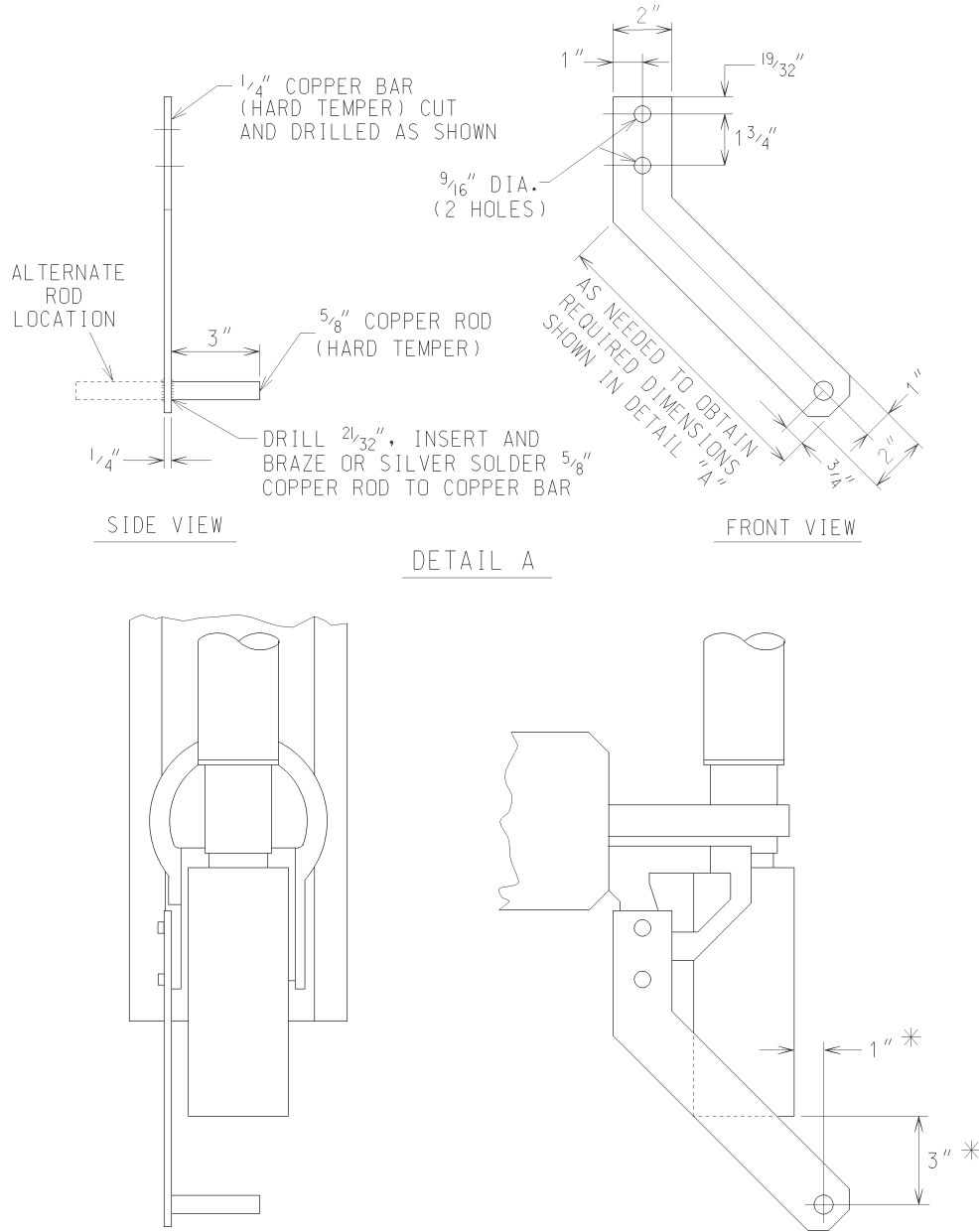

CGS File #91443F6

* REQUIRED MINIMUM DEMENSIONS

Part 1: Electrical Requirements

190.930

3-1/2" Ground Attachment Detail, 4-1/2" Depth and 7" Depth

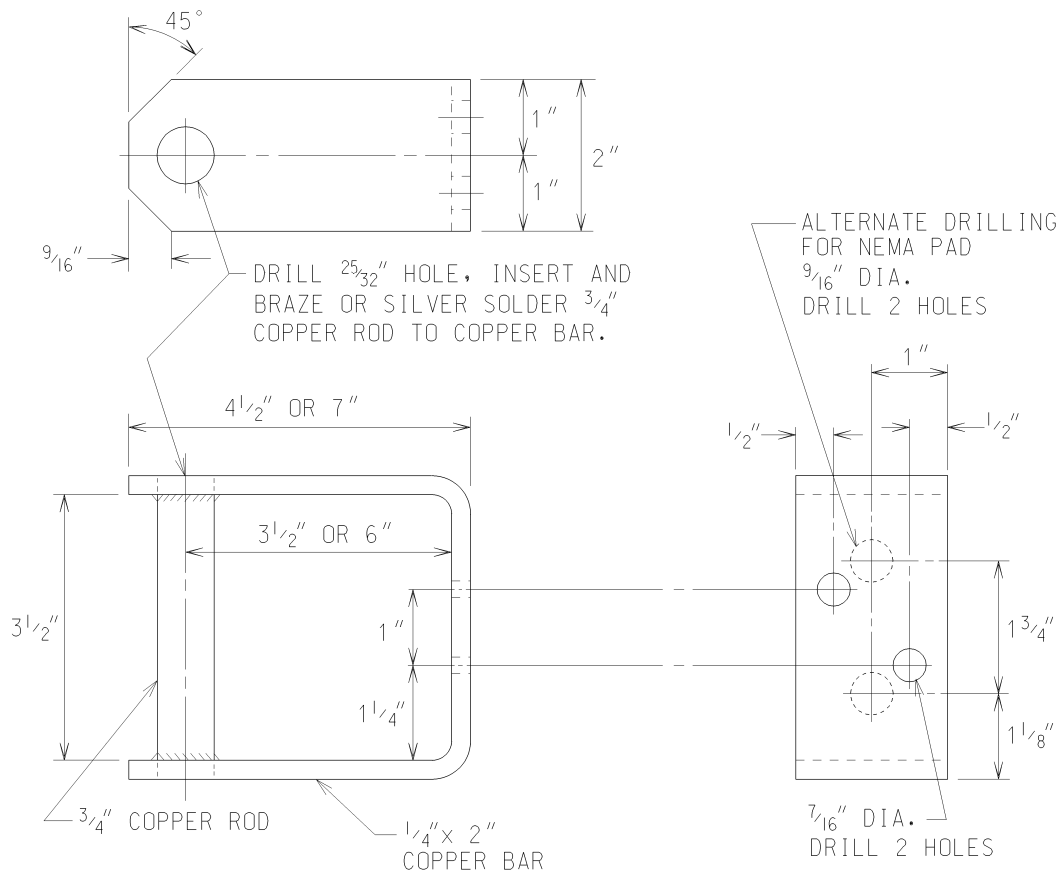

MATERIAL: $1/4'' \times 2''$ SOLID COPPER BUS BAR (HARD TEMPER) AND $3/4''$ DIAMETER SOLID COPPER ROD (HARD TEMPER).

CGS File #91443F7

Part 1: Electrical Requirements

**190.940
12" Ground Bracket**

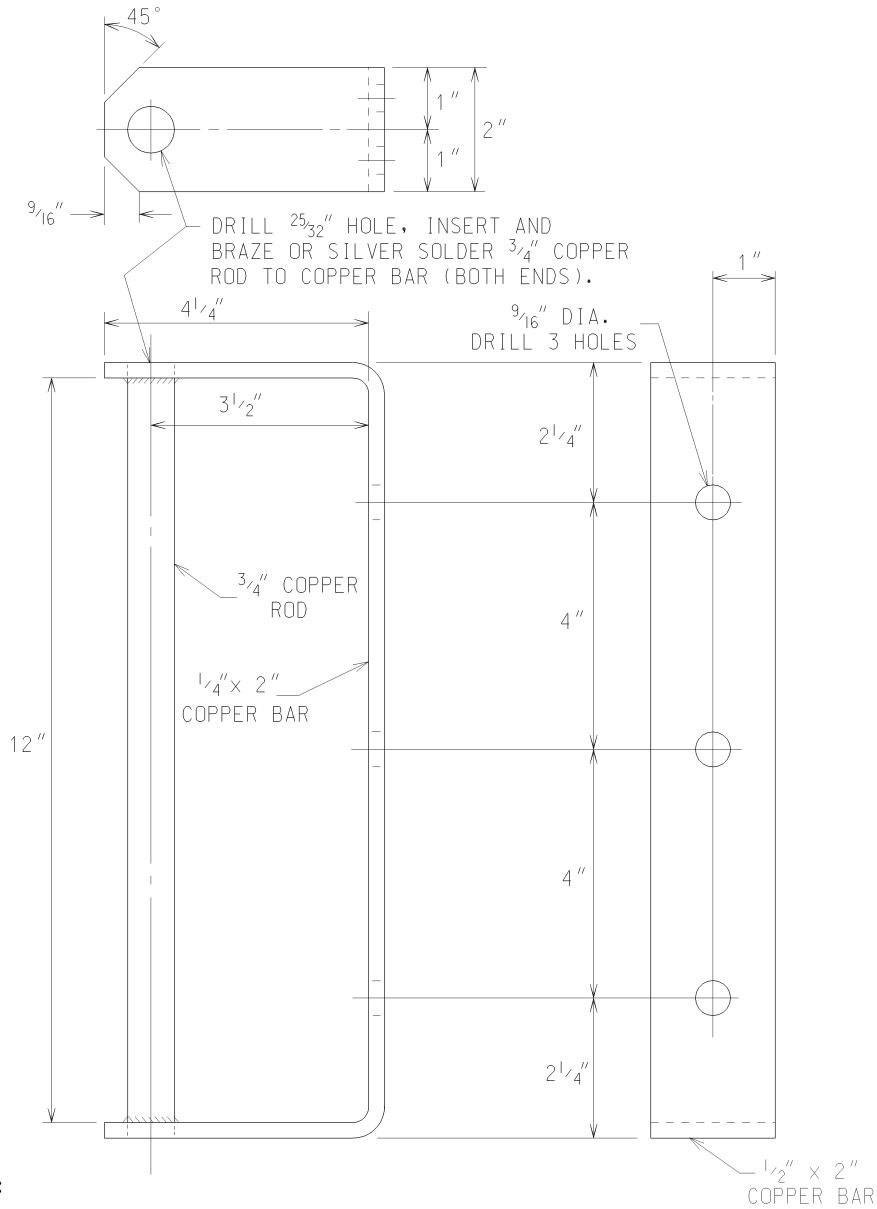

MATERIAL:
 $\frac{1}{4}$ " x 2" SOLID COPPER BUS BAR (HARD TEMPER) AND
 $\frac{3}{4}$ " DIAMETER SOLID COPPER ROD (HARD TEMPER).

CGS File #91443F8

Part 2: Physical Requirements

195) Capacitors

195.00.10) The installation of shunt capacitors for power factor correction in customer substations can have undesirable effects upon We Energies supply and customers distribution system. Care should be taken when specifying capacitors. During off peak conditions, an excessive voltage rise or a leading power factor can occur. If the capacitors are switched, a voltage dip, light flicker, high frequency ringing, etc. are possible. Switching can also result in over and under voltages which can cause variable speed drives to shut down. In some applications, capacitors may provide a low impedance path for harmonics which may result in operation of protective devices. Harmonics may contribute to a "loss of life" for capacitors. It is suggested that customers have some knowledge of their harmonic levels, or pursue a harmonic analysis prior to specifying capacitors. No general limitations on capacitor size can be made, since the factors which produce these effects vary with the location of the customer's substation, characteristics of the customers load, etc.

195.00.20) The customer shall obtain approval from We Energies for the installation of shunt capacitors. We Energies may place restrictions on the use of these capacitors with respect to voltage regulation, telephone interference or other factors. Capacitors operating at lower voltages which are switched with individual loads are exempt from any restrictions.

195.00.30) Shunt capacitors connected to three-phase, three-wire systems are not grounded to:

- avoid possible interference with telephone equipment,
- obtain better compensation for unbalanced voltages.

It may be necessary, however, to ground shunt capacitors installed at certain locations on the three-phase, three-wire systems to obtain proper coordination of protective devices.

195.00.40) Shunt capacitors installed on 13,200 volt, 13,800 volt, 26,400 volt, 34,500 volt, 69,000 volt, and 138,000 volt three-phase, three-wire systems shall be wye-connected for ungrounded operation.



Part 2: Physical Requirements

197) Parallel Generation

The Customer shall contact We Energies for specific requirements concerning power quality, relaying, liability and safety.

Part 2: Physical Requirements

200) Service Conductors

200.10) General

200.10.10) For the purpose of this discussion, service conductors are the electrical supply line(s), overhead or underground, which are installed, owned, and maintained by the Company between its distribution system and the Customer's substation. These conductors are installed, owned, and maintained by the Company even though in some cases the Customer may be required to make a financial contribution toward their cost.

200.10.20) The following paragraphs are intended to provide the Customer with general information relative to the Company's requirements for termination of service conductors and to designate a point at which division of ownership occurs. The Company will provide additional supplementary details as required, especially where underground services are involved.

200.20) Overhead Service Conductors

200.20.10) Overhead service conductors are terminated on a deadend structure provided by the Customer. The Company will provide the following data for each overhead service to a substation to assist the Customer in the design of an appropriate deadend structure.

- a) Approximate heavy loaded tension for each conductor associated with the service.
- b) Required conductor spacing and configuration at point of attachment.
- c) Minimum attachment height necessary to provide adequate clearance for service conductors.

200.20.20) Customer shall provide and install a deadend structure of adequate size and structural strength consistent with data furnished by the Company.

200.20.30) Where such deadend structures are constructed of wood, the Customer need not provide additional termination details. The Company will drill the necessary holes and furnish and install all required attachment hardware.

200.20.40) Where steel deadend structures are employed, the Customer shall furnish and install suitable attachment provisions.

200.30) Underground Service Conductors

The Company will generally provide, install and terminate the incoming service lateral cable(s) when the supply to a Customer substation is underground. The following paragraphs outline specific Company requirements for representative installations:

Part 2: Physical Requirements

200.30.10) Cubicle–Type Substations Consisting of Metal–Clad or Metal–Enclosed Switchgear Supplied Via Single Conductor Direct Burial Service Lateral Cable or Single Conductor Lead Jacketed Cables

The Customer shall furnish and install the following facilities for entry and termination of underground service lateral(s):

a) Terminal pad with NEMA standard two–hole drilling on which service lateral cables are to be terminated. The Company will connect service lateral cables to Customer's terminal pad with a NEMA standard two–hole cable lug. Such terminal pads shall be located no less than 25" for 26,400 Volts and below and 30" for 34,500 Volts above terminal compartment floor or bottom of cable trench (where present).

b) Where service lateral cables are to be terminated six feet or more above the bottom of the cable trench or cubicle compartment floor, a structural member shall be provided, securely fastened to the terminal compartment walls complete with appropriate drilling to receive service lateral cable clamps. Cable clamp supporting member shall be located three feet minimum and four feet maximum below the center line of cable termination pads. Refer to 200.40.20 to determine required cable clamp drilling.

c) Station ground bus to be extended to the vicinity of cable termination. We Energies will furnish and install the materials necessary for bonding the service lateral concentric strands or lead sheath to the station ground bus.

d) Access to the service lateral termination compartment(s) shall be by hinged door(s) at the front or rear of the switchgear. We Energies will provide the necessary padlock(s).

e) Working space in front of cable termination shall be clear of all obstructions. This working space is for the installation and maintenance of the de–energized termination. Equipment mounted in front of the termination point shall be removable to permit proper installation of service lateral cables.

f) Service lateral conduit. Conduit shall enter switchgear from the bottom. *Top and side entrances are not permitted.*

g) Indoor Substation Application Only

g.1) Cable pulling anchors (see 200.40.30 and 200.40.40), installed at the locations specified by the Company.

g.2) Customer substations located below grade shall be provided with a 12–inch wide by 6–inch (minimum) deep cable trench in the floor as specified by the Company. Depth of

Part 2: Physical Requirements

trench required for specific installation shall be such as to meet the requirements of item (a) above. Only the Company's incoming line cables shall be allowed in this trench. Exposed portions of this trench shall be covered with removable "checker plate" consistent with conditions encountered. Size requirements for opening in basement or foundation walls are shown in 200.30.50.

g.3) Customer substations located at grade level shall be provided with service entrance conduit as specified by the Company.

g.4) When indoor customer substations are not located adjacent to an outside wall or not at or below ground level, the Customer shall furnish and install the required service lateral conduit encased in concrete as specified by the Company.

h) (Outdoor Substation Application Only) The Customer shall furnish and install, according to Company specifications, that portion of the service lateral conduit which is beneath the switchgear foundation or pad.

200.30.20) Cubicle-Type Substations Consisting of Metal-Clad or Metal-Enclosed Switchgear Supplied Via Three Conductor Lead Jacketed Cable.

The Customer shall furnish and install the following facilities for entry and termination of underground service lateral(s):

a) Pothead(s) for termination of service lateral cable(s) complete with aerial lugs and connections to cubicle bus. Pothead(s) shall be mounted in incoming line terminal compartment so as to provide a 32-inch minimum clearance between bottom of the pothead wiping bell and the bottom of the cable trench or cubicle compartment floor. Pothead(s) shall be as specified by We Energies.

b) Where the service lateral termination pothead(s) is/are to be mounted six feet or more above the cubicle compartment floor or bottom of cable trench, provisions shall be made for installation of cable support bracket(s). Such provisions shall consist of a structural member securely fastened to cubicle walls drilled to receive a cable support bracket. For three conductor lead covered cable, refer to drawing 200.40.10 for the required cable support drilling. These drillings shall be located at a point 3 feet minimum and 4 feet maximum below the pothead wiping bell. One cable support for each service lateral cable will be provided and installed by We Energies

c) Station ground bus to be extended in the vicinity of pothead mounting. We Energies will furnish and install materials necessary for bonding service lateral cable sheath to ground bus.

d) Access to the service lateral termination compartment(s) shall be by hinged door(s) at the front or rear of the switchgear. We Energies will provide the necessary padlock(s).

Part 2: Physical Requirements

e) Working space in front of pothead mounting shall be clear of all obstructions. This working space is for the installation and maintenance of the de-energized pothead termination. Equipment mounted in front of the pothead shall be removable to permit installation of the pothead.

f) Service lateral conduit. Conduit shall enter switchgear from the bottom. Top or side entrances are not permitted.

g) Indoor Substation Application Only

g.1) Cable pulling anchors (see 200.40.30 and 200.40.40), shall be installed at the locations specified by We Energies.

g.2) Customer substations below grade shall be provided with a 12-inch wide by 6-inch (minimum) deep cable trench in the floor as specified by We Energies. The trench depth required for the specific installation shall be such as to meet the requirements of item (a) above. Only the We Energies incoming line cables shall be allowed in this trench. Exposed portions of this trench shall be covered with removable "checker" plate consistent with conditions encountered. The floor trench shall extend from beneath the foundation or basement wall entrance to the pothead entrance. Floor trench serving one cubicle shall not be routed through another cubicle. Size requirements for openings in basement or foundation walls are shown in 200.30.50. The location of this opening shall be as specified by We Energies.

g.3) Customer substations at grade level shall be provided with conduit as specified by We Energies.

g.4) When indoor customer substations are not located adjacent to an outside wall or not at or below ground level, the Customer shall furnish and install the required service lateral conduit encased in concrete as specified by We Energies.

h) (Outdoor Substation Application Only) The Customer shall furnish and install, according to We Energies specifications, that portion of the service lateral conduit that is beneath the switchgear foundation or pad.

Part 2: Physical Requirements

200.30.30) Outdoor Substation Constructed on Open Framework and Supplied Via Lead-Jacketed or Direct Buried Service Lateral Cable.

The Customer shall furnish and install the following facilities for entry and termination of underground service lateral(s):

- a) A pothead support consisting of a structural framework complete with appropriate drilling capable of supporting the weight of the pothead and the service lateral cable. The pothead support shall be located at the height above final grade specified by We Energies. Potheads shall be as specified by We Energies based upon the size and type cable to be used.
- b) Working space in front of pothead mounting provisions shall be clear of all obstructions for a distance of four feet.
- c) Station ground bus shall be extended to the vicinity of pothead mounting. We Energies will furnish and install materials necessary for bonding of service lateral cable sheath to the ground bus.
- d) Structural framework complete with appropriate drilling to receive service lateral cable support bracket(s) at a point 4'6" below center line of pothead mounting provisions. Refer to drawings 200.40.10 and 200.40.20 to determine the required cable support drilling. One cable support for each service lateral cable will be provided and installed by We Energies.
- e) Connecting leads from pothead aerial lug terminals to substation bus.
- f) When slab-type structural foundations are to be used, the Customer shall furnish and install, as specified by We Energies, that portion of the service lateral conduit which is beneath the foundation.

200.30.40) Special Equipment or Construction

The Company shall be consulted to obtain specific requirements for equipment and construction which cannot be classified in any of the above categories.

200.30.50) Size requirements for openings in basements or foundation walls.

Number of Ducts	Vertical Size of Wall Opening	Horizontal Size of Wall Opening
1	12"	12"
2	12"	18"
3	18"	18"

Part 2: Physical Requirements

200.40.10

Cable Support Drilling Detail for Lead Jacketed Cable

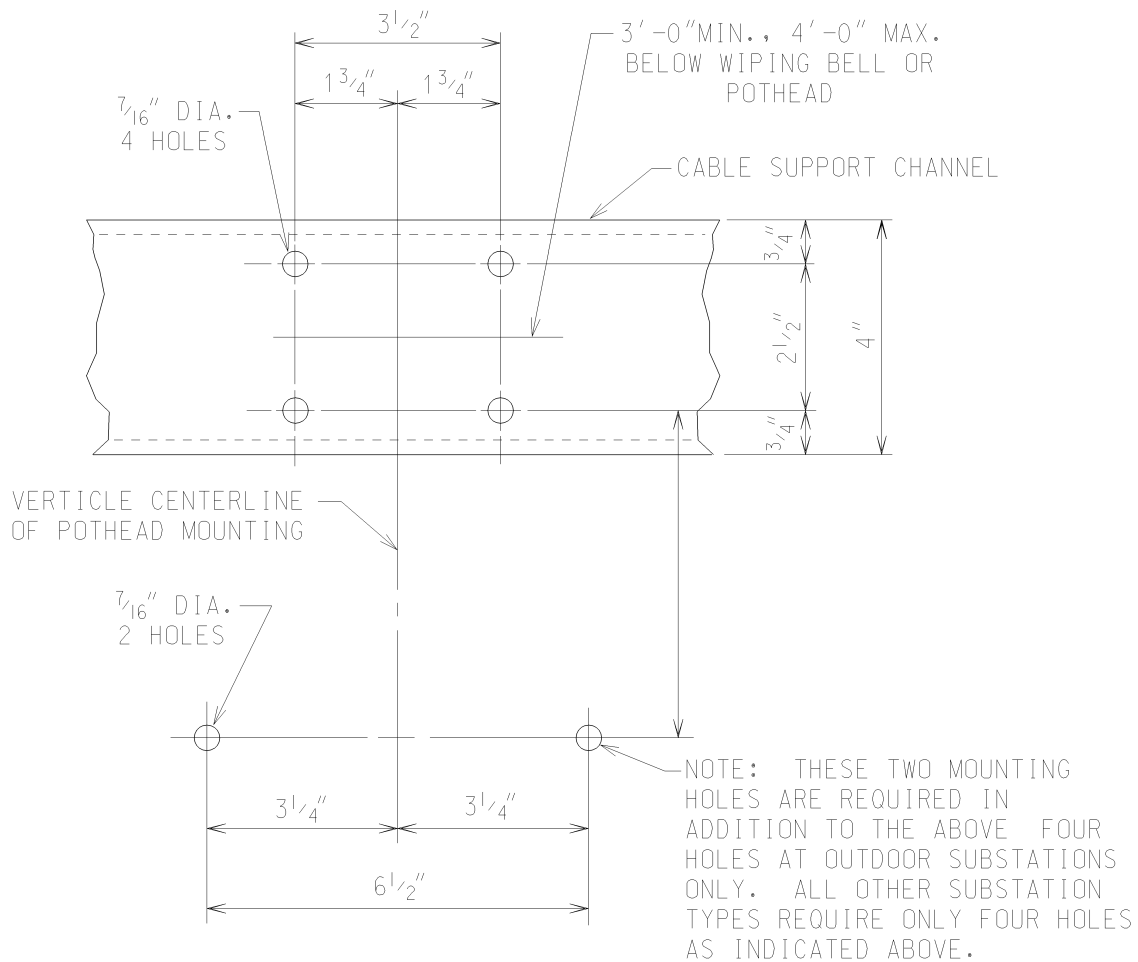

CGS File #91443F1

Part 2: Physical Requirements

200.40.20

Cable Support Drilling Detail for Direct Buried Cable

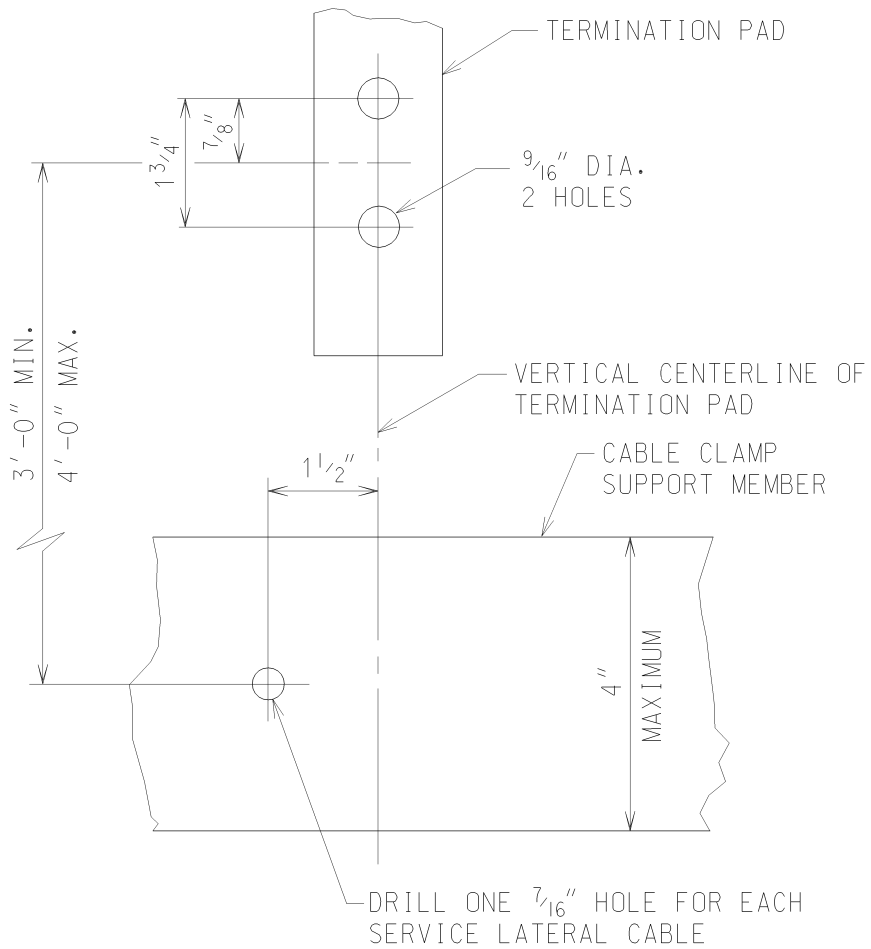

CGS File #91443F2

Part 2: Physical Requirements

200.40.30

Cable Pulling Anchor Detail

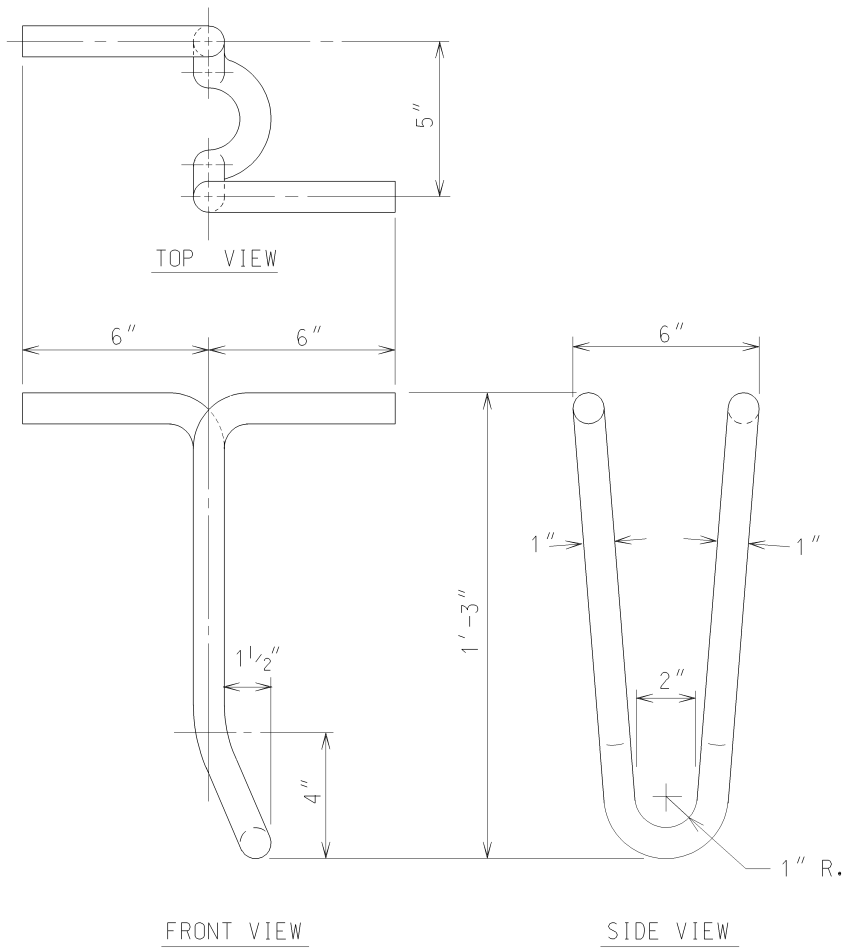

NOTE: MATERIAL, 1" ROUND STEEL, THOROUGHLY GALVANIZE AFTER BENDING. DEVELOPED LENGTH - 40 1/2".

CGS File #91443F3

Part 2: Physical Requirements

200.40.40

Installation of Cable Pulling Anchor

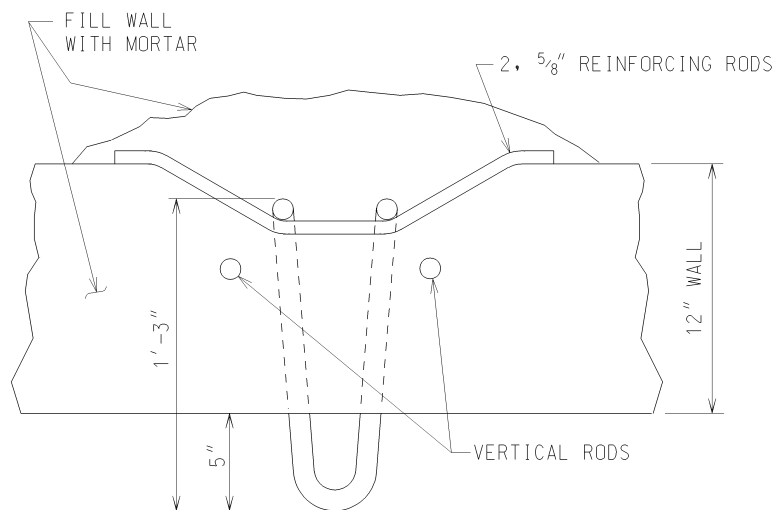
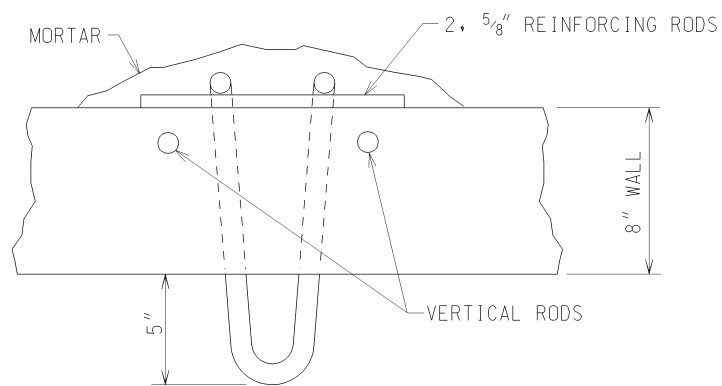

CGS File #91443F4

**Part 2: Physical Requirements****210) Routes, Easements and Space Requirements for Service Conductors**

210.00.10) When a Customer's substation is remote from We Energies distribution circuits, the service conductors are extended across private property to the Customer's service entrance equipment located either outdoors or within a building.

210.00.20) It is important in planning the route for incoming circuit(s) to avoid conflicts with the Customer's operations and existing or future underground or overhead structures.

210.00.30) We Energies will select the route over which service conductors will traverse between its distribution system and the Customer's substation.

210.00.40) This will generally be the most direct, practical and readily accessible route available consistent with existing conditions.

210.00.50) The Customer shall furnish the necessary easement and tree trimming rights to enable We Energies to construct, operate and maintain the service entrance conductors in accordance with its specifications. (Easement documents and associated exhibits will be prepared by We Energies for the Customer's signature.)

Part 2: Physical Requirements

220 Metering

220.10) General

Metering of the incoming service will normally be accomplished by the installation of a loss compensating system on the low voltage side of the customer transformer(s). For certain applications, installation of metering instrument transformers at the service voltage may be advantageous to both We Energies and to the Customer. These instrument transformers are typically connected directly after the main service disconnect switch. The appropriate method and location of metering facilities will be determined by We Energies on an individual basis. This determination will be based on overall installation cost, reliability, and the Customer's future plans for revision and expansion. Please contact the local We Energies Service Center to determine whether high voltage (primary) or low voltage (secondary) side metering will be used.

220.20) Metering at Service Voltages Above 600V

220.20.10) Metering Instrument Transformers

- a)** Instrument transformers supplied by We Energies shall be mounted by the Customer. In addition, the Customer shall make all necessary primary connections to such devices. If subsequent replacement of these devices should become necessary because of equipment failure, We Energies will perform the mounting and connection operations. The instrument transformers shall be oriented such that the polarity markers are connected to the line side of the customer bus work, and so that the secondary connection compartments face the front of the switchgear compartment.
- b)** Where indicated in the illustrations, the grounding terminals of voltage and current transformers shall be grounded. For voltage transformers, the neutral (N2) conductor shall not serve as a ground. A separate conductor, #1/0 copper minimum, is required.
- c)** The metering current and voltage transformers shall be connected on the load side of the Customer's main service disconnect.
- d)** The voltage transformers shall be connected on the line side of the metering current transformers.
- e)** Outdoor metering installations involving the use of instrument transformers at 24,900, 26,400 or 34,500 Volts require primary voltage transformer fuses. Additionally, current limiting fuses are required for outdoor use of instrument transformers at 26,400 or 34,500 Volts.
- f)** When separate primary fuses or current limiting fuses are required for metering voltage transformers, they shall be installed and connected by the Customer. We Energies will

Part 2: Physical Requirements

provide these fuses and their mountings, and will furnish specific guidelines for the proper placement of these fuses.

g) The instrument transformers shall not be used to support the bus bars or as a bus insulator.

h) The Customer shall obtain the required metering instrument transformers from the local We Energies office. Arrangements for the Customer to pickup this equipment shall be made through the local We Energies service center.

i) Exception: If the Customer desires factory installation of metering instrument transformers when such units are to be placed in metal-clad or metal-enclosed switchgear, We Energies will, when instructed to do so, forward them to the manufacturer. Customer instructions for such an arrangement shall be directed to the local We Energies service center as early as possible. This allows We Energies to reserve specific transformers for the job, thereby allowing the manufacturer to design the metering cubicle accordingly. Instructions shall include the following:

- Name of the switchgear manufacturer
- Specific address of plant to which units are to be shipped
- Name and title of the individual to whom the units are to be directed
- Customer's purchase order number (for reference)
- Approximate date by which units will be required at factory

We Energies will exercise every effort to assure prompt and safe delivery of instrument transformers to the manufacturer, but will not assume responsibility for delays caused by loss or damage of such equipment in transit.

220.20.20) Associated Metering Equipment

a) The Customer shall provide and install suitable meter mounting devices as specified below. The meter mounting devices and conduit shall be bonded and grounded in accordance with the Wisconsin or Michigan State Electrical Codes and applicable local ordinances. All conduit shall be galvanized rigid or galvanized intermediate. Meter mounting devices shall be located and mounted in accordance with the We Energies "General Information" section of the *Electric Service and Metering Manual*, and conform to the "General Requirements of Meter Mounting Devices" in Section D (except only the transformer rated meter sockets listed in 220.20.20.c are permitted for primary rate accounts. The sockets in 220.20.20.c have sufficient room to accommodate the cellular telephone connections).

Part 2: Physical Requirements

b) Meter mounting devices shall consist of a Transformer Rated Meter Socket from 220.20.20.c and a waterproof, sealable, enclosure with minimum inside dimensions of 16" x 14" x 6" containing a 3/4" wood mounting board. The connection between the meter socket and the enclosure is to be made with 1/2" galvanized rigid or galvanized intermediate conduit. See 220.20.35

Exception: When the switchgear is equipped with integral meter mounting provisions as described in 220.20.30.d.

c) Acceptable transformer rated meter sockets for customer substations.

Supplier	Socket Catalog Numbers	
	3-Phase, 3-Wire	3-Phase, 4-Wire
Erickson	W-330	W-340-SS
Meter Devices	601U3128A8-302	601U3128A13-303
RJB	MS2033-8	MS2034-13

d) The Customer shall install 1¼" galvanized rigid or galvanized intermediate conduit between the meter socket and the instrument transformer location. The conduit run shall be exposed where practical and may be up to 40 feet in length without approval from We Energies.

e) All required revenue meters, metering conductors or cables, test switches, relays and other equipment not previously mentioned will be furnished and installed by We Energies.

220.20.30) Metering Cubicle Unit for Metal-Clad or Metal-Enclosed Switchgear Applications

a) The Customer shall furnish and install a We Energies approved metering cubicle unit where We Energies metering instrument transformers are to be mounted. This unit shall be specifically designed for metering equipment only, and no devices other than those required for support and connection of metering instrument transformers will be permitted.

b) Switchgear enclosure surfaces shall not be used as physical support for metering equipment or any other items unless specifically designed for that purpose.

c) For cubical-type installations with remote meter enclosures, the required meter conduit shall be terminated inside the cubicle containing instrument transformers with an appropriate conduit bonding bushing. The We Energies preferred location for this conduit is the front third of the metering cubicle compartment in an unobstructed area. Contact the switchgear manufacturer for a more precise location for this conduit.

Part 2: Physical Requirements

d) The Customer may choose to provide meter mounting space (within the metering cubicle). This compartment shall have minimum dimensions of 44" high x 30" wide x 14" deep. This space shall be completely separated from all high voltage equipment by sheet metal barriers.

e) Where two metering cubicles are provided as part of one switchgear lineup, and space is provided for mounting meters in those cubicles, conduit shall be run between the metering cubicles. This conduit shall be 1/4" galvanized rigid or galvanized intermediate and shall be terminated in each cubicle and appropriately bonded.

Part 2: Physical Requirements

220.20.35

Typical Arrangement of the Transformer Rated Meter Socket and the Cellular Telephone Enclosure

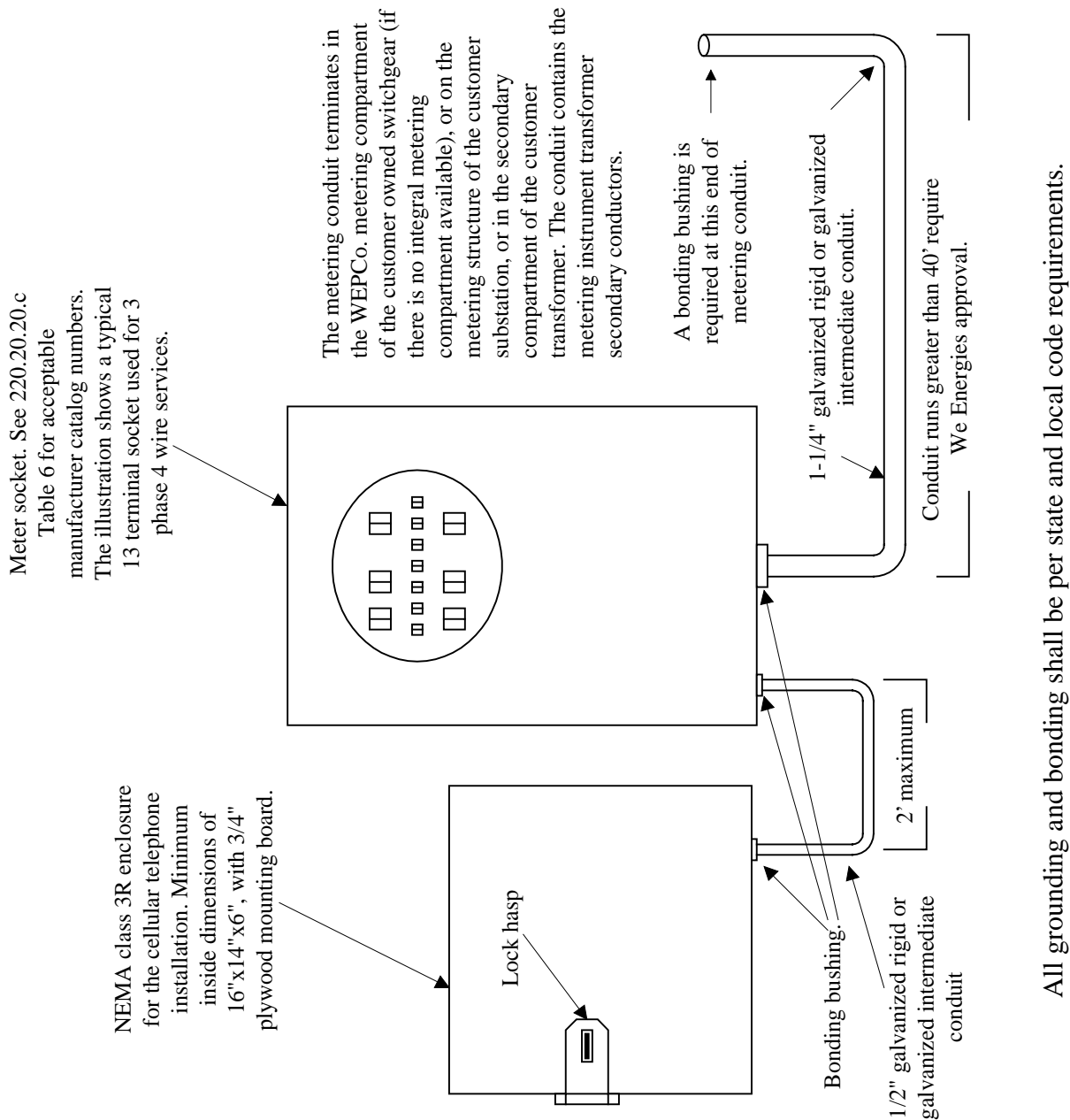

All grounding and bonding shall be per state and local code requirements.

Part 2: Physical Requirements

220.20.40) Metering Instrument Transformer Arrangement for Outdoor, Open-Type Substations 34,500 Volts and Below

- a) Where the substation design utilizes a wood structure, the required 1¼" meter conduit shall be terminated on a vertical column (pole) of the structure on which metering instrument transformers are located. The termination shall be made at a point 8 feet above finished grade. We Energies will provide and install the necessary support and termination materials for extension of the metering cable beyond this point.
- b) Where the substation design utilizes a steel structure, 1" minimum conduit shall interconnect the secondary terminal boxes of all metering instrument transformers. 1¼" minimum size metering conduit shall be used between the meter enclosure and the first conduit body junction point.
- c) See 220.40 for additional requirements.

220.20.50) Street Light Transclosures

Meter enclosures used for housing metering associated with street light transclosures shall have a minimum depth of 10½" to accommodate time of use meters.

220.30) Loss Compensated Metering

220.30.10) At installations where secondary side metering is chosen by We Energies, the revenue meter will be programmed to electronically compensate for the Customer's transformer and line losses. For these applications, the Customer shall be required to provide We Energies with a certified test report of the power transformer to ensure accurate compensation.

220.30.20) Approved meter mounting devices for installations metered at 600 volts or below are identical to the devices specified for metering above 600 volts and are listed in 220.20.20.c. All other requirements for installations metered at 600 volts or below are detailed in the *Electric Service and Metering Manual*.

220.40) Illustrations

220.40.00) The following illustrations show examples of typical metering instrument transformer installations in Customer owned metal enclosed or metal clad substations and in Customer-owned outdoor open-type substations for all We Energies system voltages.

220.40.10) Metering switchgear units for application on 3 phase 4 wire system voltages of 4,160 Volts and below.

Part 2: Physical Requirements

220.40.20) Metering switchgear units for application on 3 phase 3 wire and 3 phase 4 wire system voltages above 4160 Volts up to and including 13,800 Volts.

220.40.30) Metering switchgear units for application on 3 phase 4 wire distribution system voltages above 13,800 Volts, up to and including 24,900 Volts.

220.40.40) Metering switchgear units for application on 3 phase 3 wire and 3 phase 4 wire system voltages above 13,800 Volts up to and including 26,400 Volts.

220.40.50) Metering switchgear units for application on 3 phase 3 wire and 3 phase 4 wire 34.5 kV systems where available.

220.40.60) Outdoor metering structure for 3 phase 4 wire distribution system voltages 15kV and below

220.40.70) Outdoor metering structure for the 24.9kV 3 phase 4 wire distribution system.

220.40.80) Outdoor metering structure for the 26.4kV and 34.5kV 3 phase 3 wire and 3 phase 4 wire systems.

Part 2: Physical Requirements



220.40.10

5kV Metering Switchgear Unit

3-Phase 4-Wire Services — Typical Arrangement

Grounding details on the **current** transformers shall be interconnected and grounded using a minimum conductor size of 1/0 copper.

Grounding details on the **voltage** transformers shall be interconnected and grounded using a minimum conductor size of 1/0 copper.

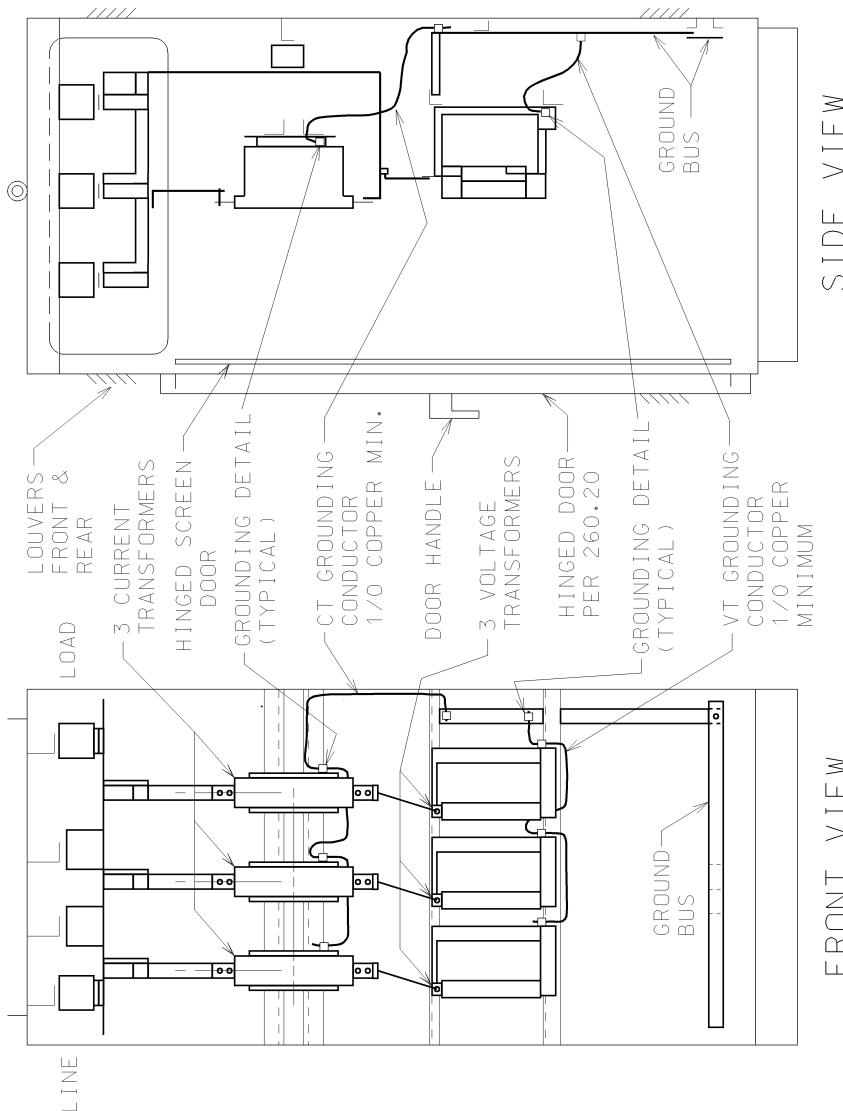

CGS File #38065F1

5kV Metering Switchgear	
Required Minimum Clearances	60kV BIL
Phase to Phase	4.5 Inches
Phase to Ground	3.0 Inches
Phase to Barrier	2.0 Inches

Part 2: Physical Requirements



220.40.20

15 kV Metering Switchgear Unit

3-Phase 3-Wire and 3-Phase 4-Wire Services — Typical Arrangement

Grounding details on the **current** transformers shall be interconnected and grounded using a minimum conductor size of 1/0 copper.

Grounding details on the **voltage** transformers shall be interconnected and grounded using a minimum conductor size of 1/0 copper.

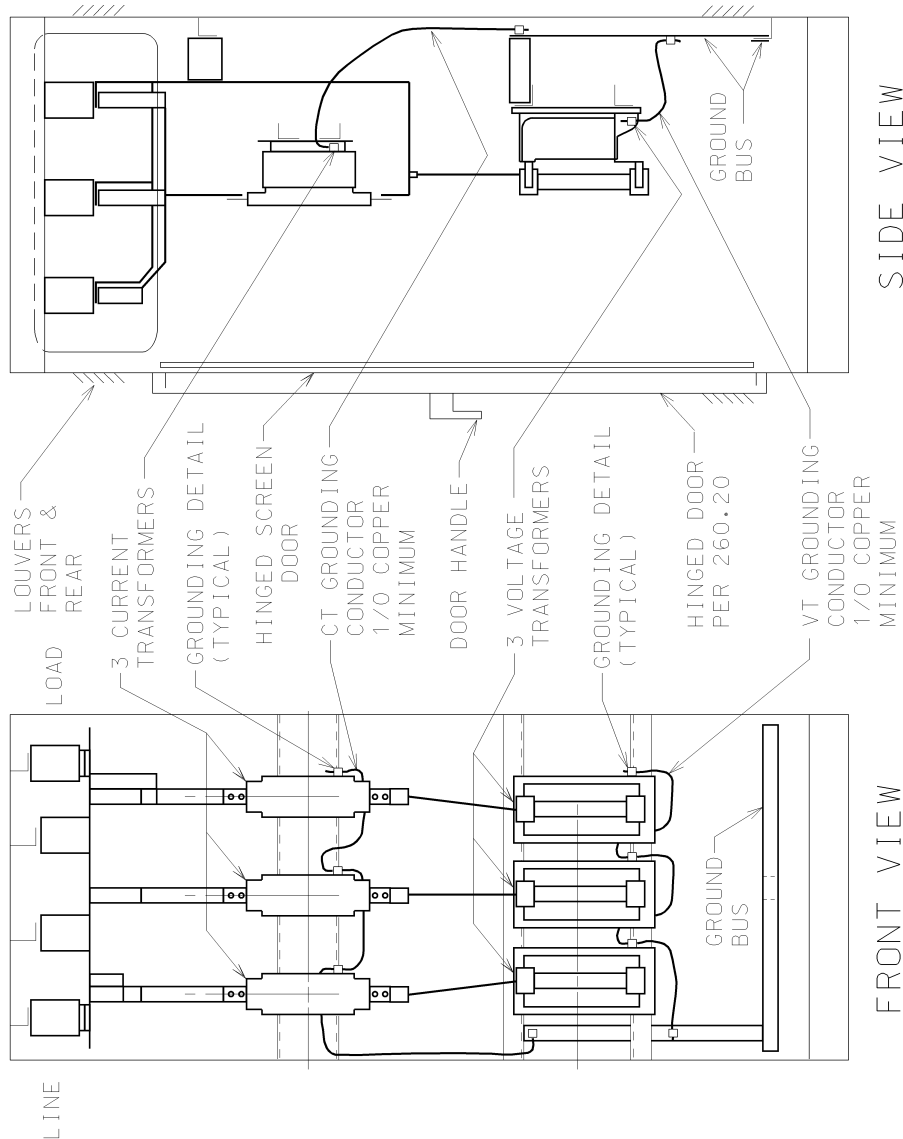

CGS File #38065F3

15kV Metering Switchgear		
Required Minimum Clearances	95kV BIL	110kV BIL
Phase to Phase	7.5 Inches	9.0 Inches
Phase to Ground	5.0 Inches	6.5 Inches
Phase to Barrier	2.0 Inches	2.0 Inches

Part 2: Physical Requirements



220.40.30

25 kV Metering Switchgear Unit

3-Phase 4-Wire Services — Typical Arrangement

Grounding details on the **current** transformers shall be interconnected and grounded using a minimum conductor size of 1/0 copper.

Grounding details on the **voltage** transformers shall be interconnected and grounded using a minimum conductor size of 1/0 copper.

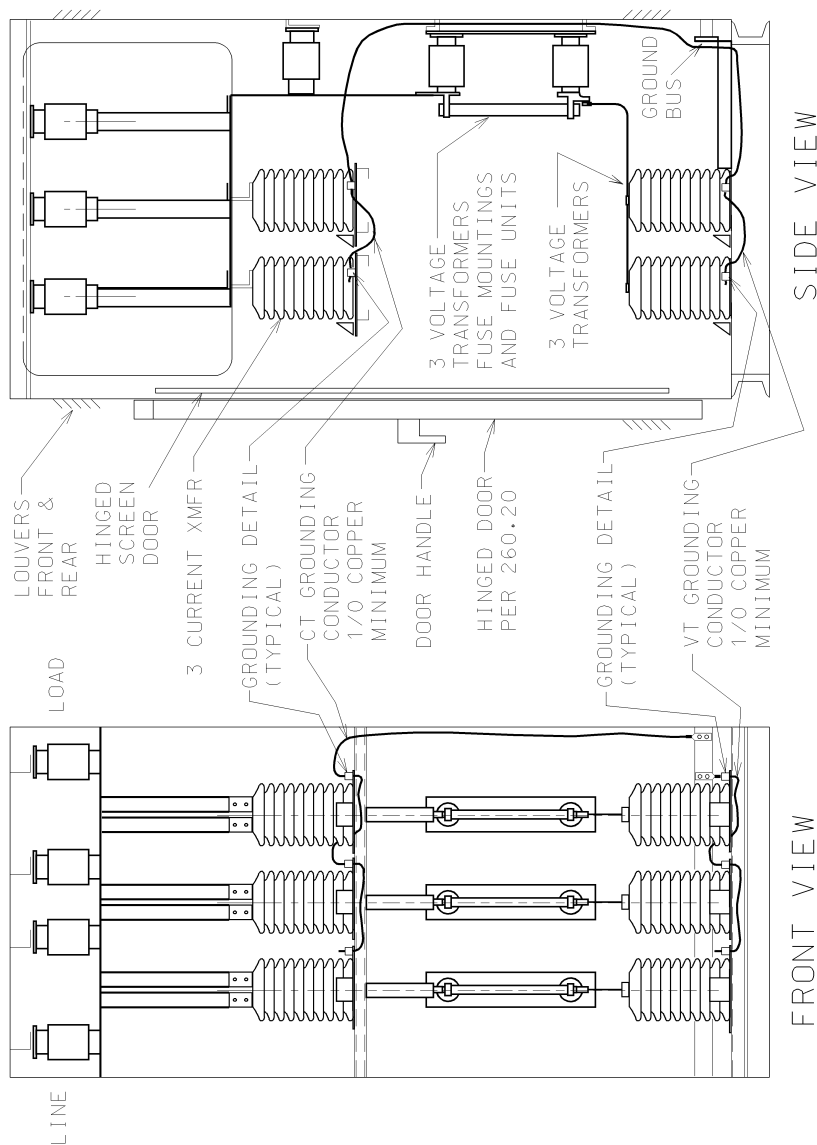

CGS File #38065F4

24.9kV Metering Switchgear	
Required Minimum Clearances	125kV BIL
Phase to Phase	10.5 Inches
Phase to Ground	7.5 Inches
Phase to Barrier	2.5 Inches

Part 2: Physical Requirements

220.40.40

26.4 kV Metering Switchgear Unit

3-Phase 3-Wire and 3-Phase 4-Wire Services — Typical Arrangement

Grounding details on the **current** transformers shall be interconnected and grounded using a minimum conductor size of 1/0 copper.

Grounding details on the **voltage** transformers shall be interconnected and grounded using a minimum conductor size of 1/0 copper.

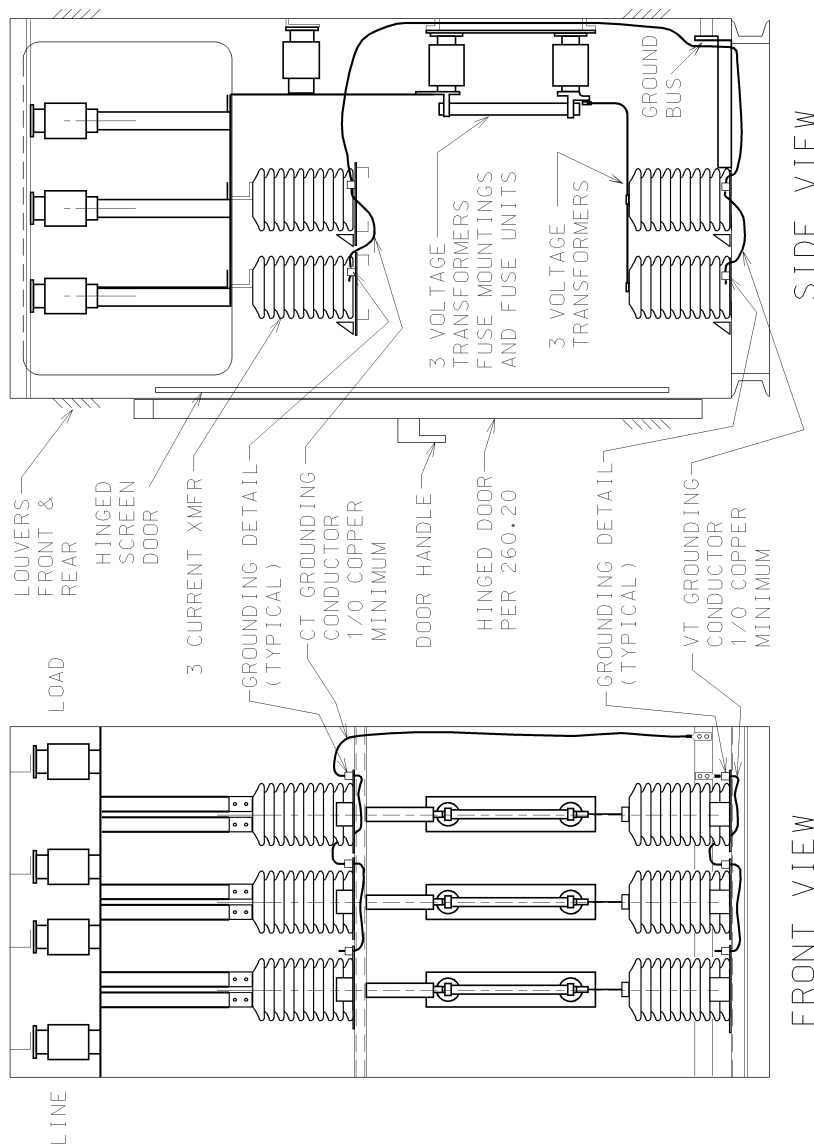

CCS File #38065F4

26.4kV Metering Switchgear		
Required Minimum Clearances	125kV BIL	150kV BIL
Phase to Phase	10.5 Inches	12.5 Inches
Phase to Ground	7.5 Inches	9.5 Inches
Phase to Barrier	2.5 Inches	2.5 Inches

Part 2: Physical Requirements

220.40.50

34.5 kV Metering Switchgear Unit

3-Phase 3-Wire and 3-Phase 4-Wire Services — Typical Arrangement

Grounding details on the **current** transformers shall be interconnected and grounded using a minimum conductor size of 1/0 copper.

Grounding details on the **voltage** transformers shall be interconnected and grounded using a minimum conductor size of 1/0 copper.

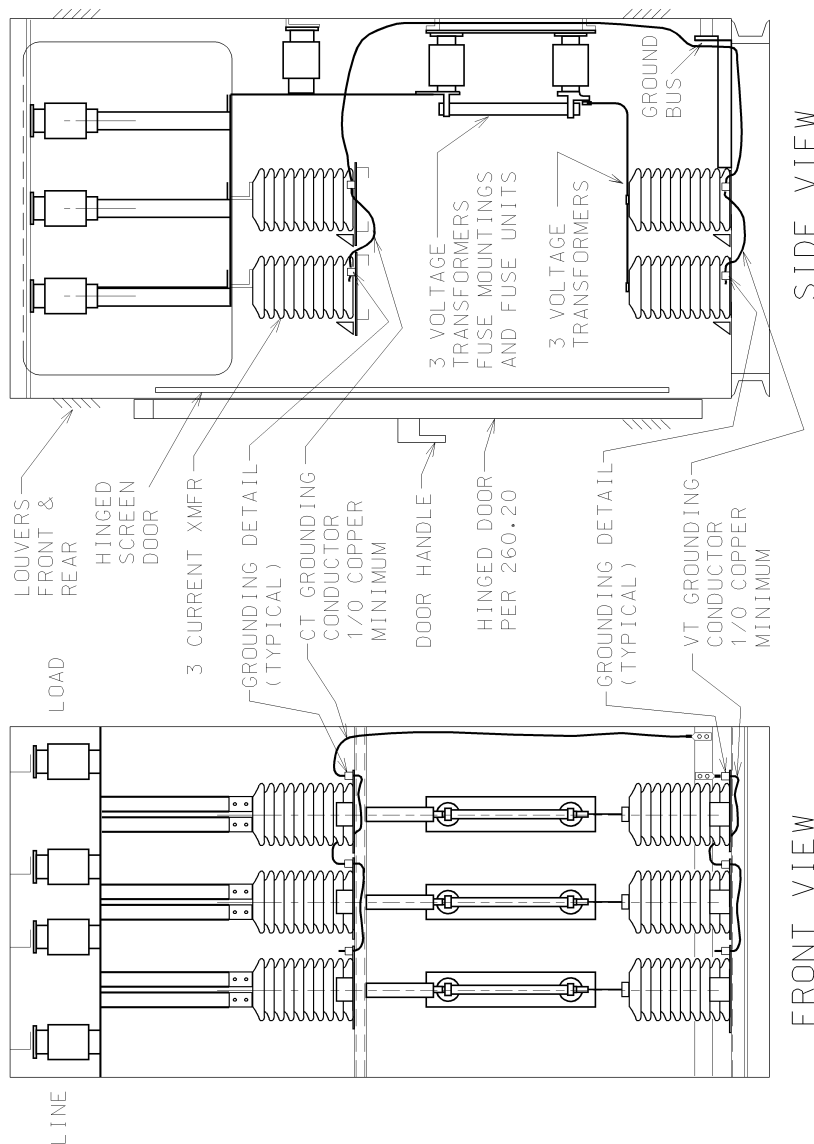

CCS File #38065F4

34.5kV Metering Switchgear		
Required Minimum Clearances	150kV BIL	200kV BIL
Phase to Phase	12.5 Inches	18 Inches
Phase to Ground	9.5 Inches	13 Inches
Phase to Barrier	3.0 Inches	3.0 Inches

Part 2: Physical Requirements

220.40.60

**System Voltages 15kV and Below: 3-Phase 3-Wire and 3-Phase 4-Wire Services
Primary Metering Structure for Outdoor Open Style Substations — Typical Arrangement**

Note 1: Grounding details on the **current** transformers shall be interconnected and grounded using a minimum conductor size of 1/0 copper.

Note 2: Grounding details on the **voltage** transformers shall be interconnected and grounded using a minimum conductor size of 1/0 copper.

Note 3: This clearance may be reduced to 9'0" if the installation is within a substation enclosure as described in Section 250.

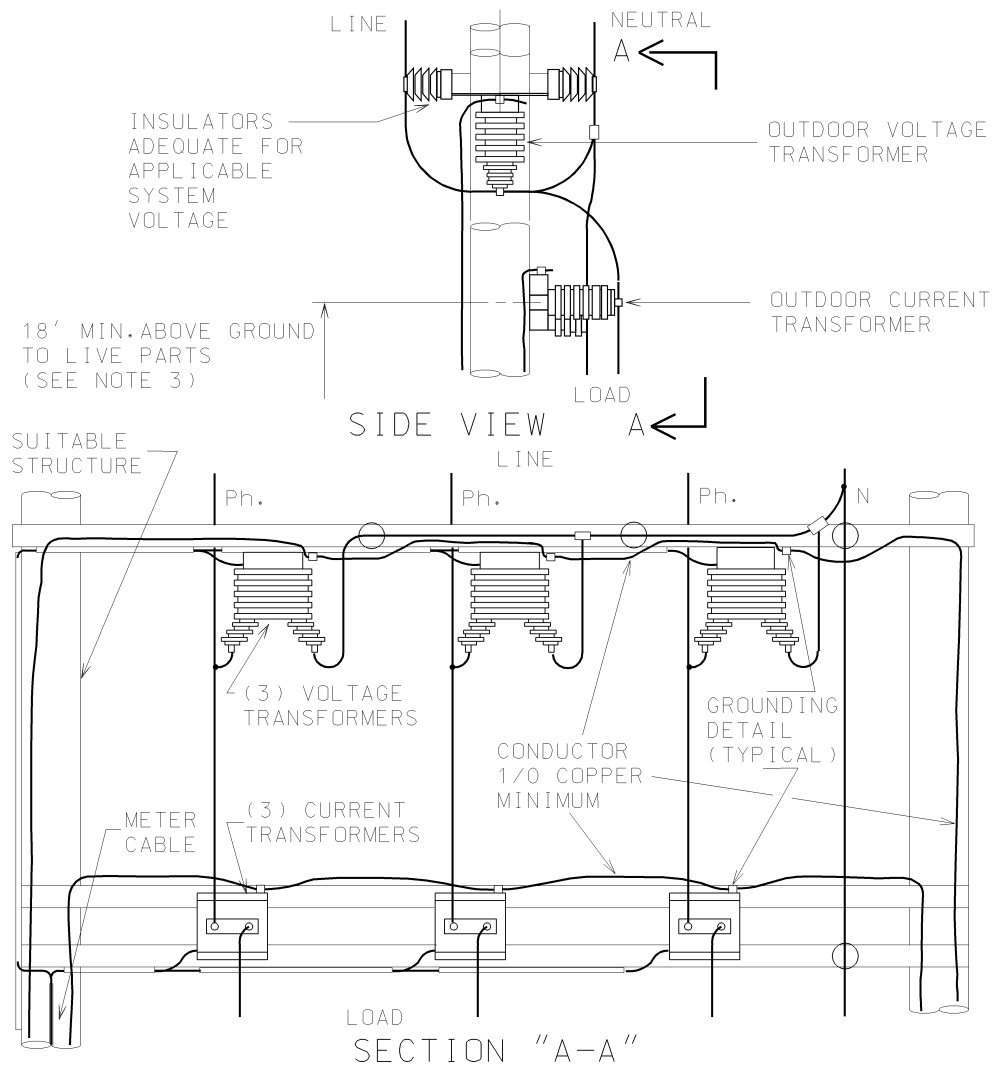

CGS File #38065F7

Part 2: Physical Requirements

220.40.70

**Distribution System Voltages 25kV and Below 3-Phase 4-Wire Services
Primary Metering Structure for Outdoor Open Style Substations — Typical Arrangement**

Note 1: Grounding details on the **current** transformers shall be interconnected and grounded using a minimum conductor size of 1/0 copper.

Note 2: Grounding details on the **voltage** transformers shall be interconnected and grounded using a minimum conductor size of 1/0 copper.

Note 3: This clearance may be reduced to 9'6" if the installation is within a substation enclosure as described in Section 250.

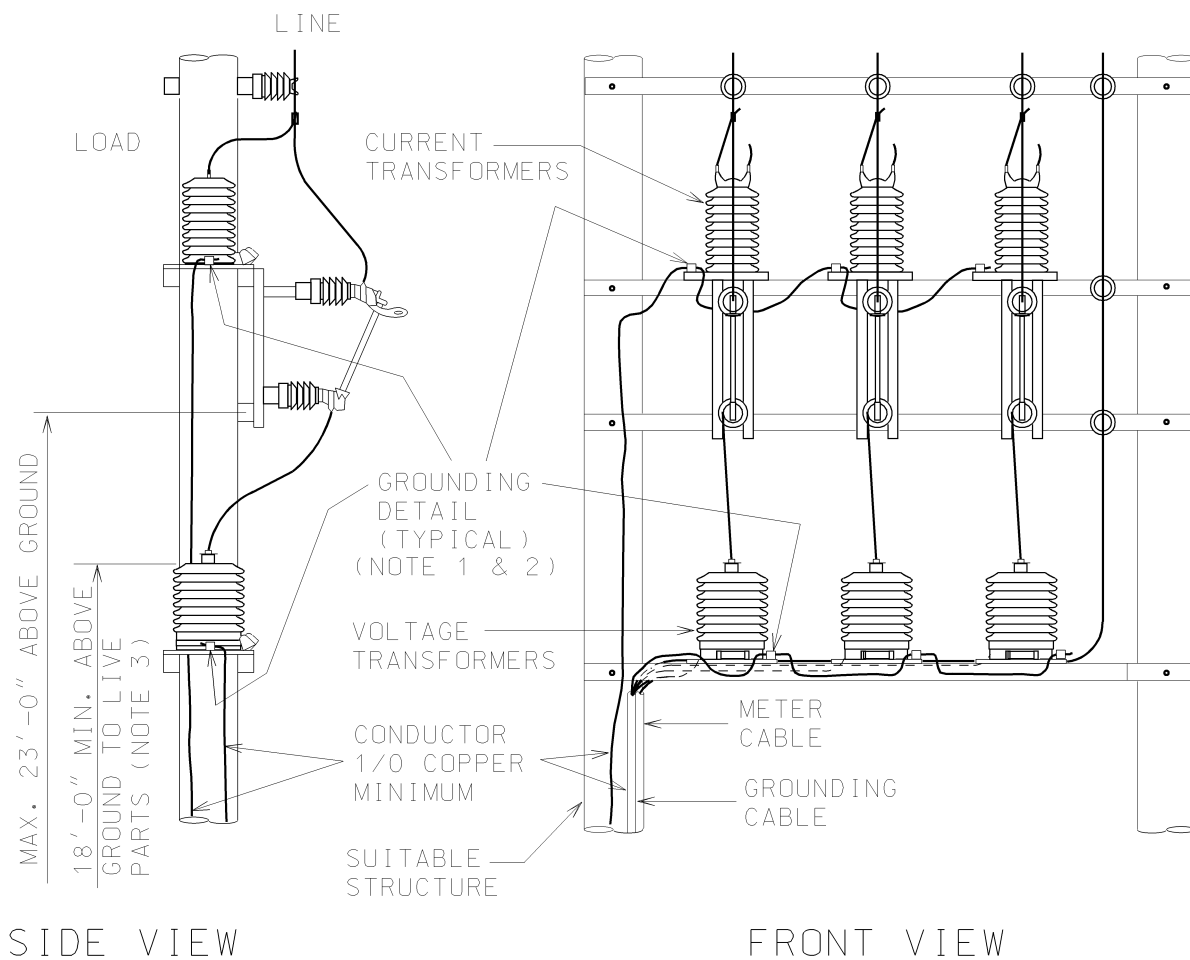

SIDE VIEW

FRONT VIEW

CGS File #38065F8

Part 2: Physical Requirements



220.40.80

**System Voltages 26.4kV and 34.5kV, 3-Phase 3-Wire and 3-Phase 4-Wire Services
Primary Metering Structure for Outdoor Open Style Substations — Typical Arrangement**

Note 1: Grounding details on the **current** transformers shall be interconnected and grounded using a minimum conductor size of 1/0 copper.

Note 2: Grounding details on the **voltage** transformers shall be interconnected and grounded using a minimum conductor size of 1/0 copper.

Note 3: When using wood pole and crossarm construction, the ground lead for the voltage transformers shall form a loop which ties the driven ground rods together or connects to the ground system inside the substation.

Note 4: The fault current limiting fuse terminal shall not rest on the voltage transformer insulation.

Note 5: This clearance may be reduced to 9'6" (26.4kV systems) or 9'10" (34.5kV systems) if the installation is within a substation enclosure as described in Section 250.

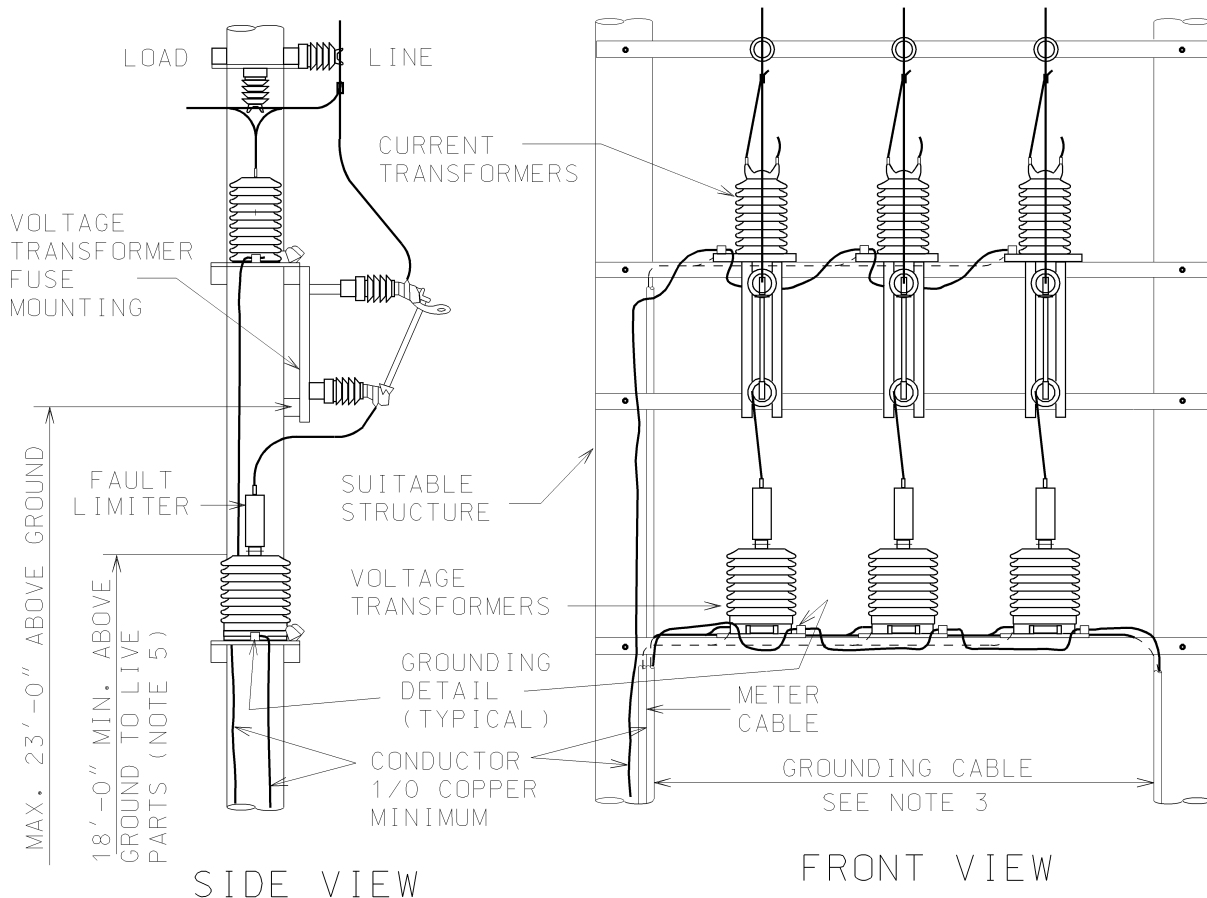

CGS File #38065F10

Part 2: Physical Requirements

230) Clearance and Spacing

230.10) General

Customer substations shall be constructed in accordance with the requirements of the Wisconsin and/or Michigan State Electrical Codes (all volumes) and applicable local codes or ordinances with respect to live part clearances, spacing of equipment and conductors, and working space. This includes meeting all minimum clearances for live parts as listed in NEC 490–24.

230.20) Operating Space for Open–Type Fuse Installations

For metering voltage transformer fuses, the customer shall provide inside the substation a clear, level area, which extends three feet outside each outboard fuse mounting and a minimum of six feet out from the face of the mounting structure. In addition to the space required to operate the fuses, the substation design shall provide an area adjacent to the fuse structure in which to assemble, raise, and lower the switch stick. The switch stick should be two feet shorter than the distance from grade to the lower support point or lower hinge point of the fuse. The clear area shall be four feet wide and four feet longer than the switch stick, both in ground area and in the path of the stick as it is raised.

Part 2: Physical Requirements**240) Signs and Identification****240.10) General**

240.10.10) The Customer shall provide a schedule of nameplates and signs for We Energies acceptance prior to construction of substation. Such schedule shall clearly indicate the inscription of each sign or nameplate, and specify the intended location of each.

240.10.20) To cover unusual installations We Energies may require additional signs and markings at the time of installation.

240.20) Location

240.20.10) Signs used to identify equipment are mounted either directly on the equipment or on the station structure close to the equipment identified.

240.20.20) Signs shall not hinder the operation of equipment, reduce electrical clearances or in any way present a hazard.

240.20.30) Danger and Caution signs shall be located so that there is sufficient time to read the warning before encountering the hazard.

240.20.40) Signs giving operating instructions shall be conspicuously located at the operating point either on or near the equipment involved.

240.30) Minimum Sign Requirements for Typical Customer Substations

Before the substation is placed in service, the Customer shall furnish the signs for the style of substation listed in 240.30.10 or 240.30.20.



Customer Substation Manual

08/05/02

Part 2: Physical Requirements

240.30.10) Signs for Outdoor Open Type Substations:

DESCRIPTION	LOCATION
No Admittance	Outside face of all entrance gates or doors in station fence or enclosure.
Danger High Voltage	Outside face of station fence or enclosure spaced not more than 40 ft. apart.
Phase Identification Letters A, B, and C	Adjacent to deadend attachment or potheads of all incoming lines.
CAUTION: Do Not Open Any Disconnect Switches When Carrying Load OR CAUTION: Do Not Open Any Disconnect Fuses When Carrying Load	On structure near disconnect switches or disconnecting type fuses in a conspicuous place.
Incoming Line Loadbreak Switch or Incoming Line Circuit Breaker	On or near service loadbreak switch operating handle or service circuit breaker.

240.30.20) Signs for Indoor or Outdoor Substations Consisting of Metal-Enclosed Switchgear With Loadbreak Switches and Fuses, or With Draw-Out Circuit Breakers

DESCRIPTION	LOCATION
NOTICE: Keep This Doorway Free of Obstructions At All Times	Outside face of each gate or door specifically provided as an entrance or exit from station enclosure or vault.
DANGER: High Voltage	On all doors which give access to high voltage components.
Incoming Line Termination	On door which gives access to an incoming line termination, but the associated load break switch.
Incoming Line Loadbreak Switch	Center of front door on all incoming line compartments which contain the designated equipment.
L.B. XXX (A two to five digit number as designated by We Energies)	Above loadbreak switch operating handle on all incoming line compartments which contain operable loadbreak switches in substations served by two or more lines.
Service Fuses	Center of door on compartment which contains the designated equipment.
We Energies Meters	Center of door on compartment which contains the designated equipment.
We Energies Metering Transformers	Center of door on compartment which contains the designated equipment.

Part 2: Physical Requirements

250) Enclosures, Fences, and Surfacing – Outdoor Open Type Substations

250.00.10) Customer shall furnish and install a suitable fence or enclosure for outdoor, open-type substations in accordance with the requirements of the Wisconsin and/or Michigan State Electrical Codes (all volumes) and/or applicable local codes and ordinances.

250.00.20) Initial fence construction and final grading shall be done carefully so as to close all voids between the bottom of fence or gate and final grade which may jeopardize the integrity of the enclosure. Also, reasonable maintenance shall be performed, as required, to close such voids which appear after the initial installation due to settling or erosion.

250.00.30) The Customer shall provide and install crushed limestone surfacing outside the substation fence when the fence ground is interconnected with the station ground grid as directed in Section 180.

Part 2: Physical Requirements



260) Metal-Enclosed and Metal-Clad Service Entrance Switchgear

260.10) General

Metal-enclosed and metal-clad switchgear assemblies for installation as service equipment shall be constructed in accordance with the latest revisions of applicable ANSI and NEMA Standards and appropriate electrical codes.

260.20) Doors

260.20.10) All compartments containing We Energies cables, terminations and metering equipment shall meet the ANSI C57-12.28 latest revision #14 AWG wire tamper resistance provision.

260.20.20) All compartments shall be equipped with hinged access doors. All doors shall be fitted with concealed hinges and be secured by a sturdy 3-point latching mechanism operated by a single padlockable handle.

260.20.30) Doors handles on compartments in which We Energies supply cable terminate, compartments containing service switch or breaker and compartments containing We Energies metering transformers shall, in addition to the above requirements, accept a standard We Energies. padlock with 21/64 inch shackle and include a single captive recessed penta-head bolt. The door handle and penta-head bolt provision shall be designed so that:

- a) The padlock shall block access to the penta-bolt.
- b) The door handle cannot be operated until the padlock is removed and the penta-bolt is loosen.
- c) The padlock cannot be install until the handle is closed and the penta-bolt tightened.

260.20.40) Doors on compartments in which We Energies supply cable terminate, compartments containing service switch or breaker and compartments containing We Energies metering transformers shall not be secured by key or mechanical interlocks. The service switch or breaker may have a key cylinder interlock that releases keys for downstream devices but does not interfere with the operation of the compartment door.

260.30) Windows

Inspection windows shall be provided in the door of each compartment that contains a switch so that the open and closed positions of all switch blades are readily discernible from the exterior of the enclosure.

Part 2: Physical Requirements

260.40) Detachable Panels

260.40.10) Detachable panels on compartments in which We Energies supply cables terminate, compartments containing service switches or breakers, compartments containing We Energies metering transformers, and compartments containing unprotected bus shall be secured so they cannot be removed from the outside of the compartment. The locking provisions shall not be circumvented.

260.40.20) Panels secured by external fasteners using specialty drivers such as hex, torx, star or similar do not meet the intent of this requirement.

260.50) Screen Doors

260.50.10) All compartments that contain We Energies supply cable terminations, service switches, We Energies metering transformers and feeder fuses shall be equipped with hinged screen doors to isolate all high voltage parts.

260.50.20) Service switch compartments equipped with slide-in isolating barriers shall be provided with hinged split screen doors.

- a) The upper screen door shall isolate only the portion of the switch above the slide-in barrier.
- b) The lower screen door shall extend from just below the upper screen door to the bottom of the compartment.
- c) The arrangement and location of the split screen doors and the isolating barriers shall permit the installation of the isolating barriers when only the lower screen door is open.
- d) Feeder Switch/fuse compartments shall be equipped with a hinged screen door isolating only the switch. An additional hinged screen isolating the feeder fuses is required unless the compartment door is interlocked to the feeder switch operating handle so that the main door can be opened only with the switch open.

260.60) Slide-In Barriers

260.60.10) The service switch compartment(s) shall be equipped with slide-in barriers whenever the switchgear main bus can be energized from more than one source (i.e. multiple We Energies feeders or a We Energies feeder and customer owned generator feeder).

260.60.20) The slide-in barriers shall insert on insulated rails and slide between the stationary and movable contacts of the disconnect switch.

Part 2: Physical Requirements

260.60.30) Slide-in barriers shall be installable using a shotgun type hotstick.

260.60.40) Slide-in barriers shall be fabricated from fiberglass board material.

260.60.50) When installed the barrier shall not contact live parts.

260.60.60) Provisions to store these barriers, when not in use, shall be provided on the outside of the screen door or on the inside of the compartment door.

260.60.70) Storage of slide-in barriers shall not obstruct the viewing window.

260.70) Insulators

260.70.10) Skirted insulators of appropriate ratings shall be used between any connection of a live part and a grounded surface or between live parts of different phases.

260.70.20) The insulators shall be installed so that water will not pool on the skirts.

260.70.30) The insulators may be made of porcelain, cycloaliphatic epoxy resin or silicone rubber.

260.70.40) Requirements for insulators apply to all insulators on unprotected bus which support:

- a) Interrupter switches,
- b) Fuse mountings on the source side of the fuse,
- c) switch push rods,
- d) interphase insulators.

260.75) Clearances

The minimum clearance of live parts within metal enclosed switchgear shall be as specified below in 260.75.10. Minimum clearance between live parts and insulated barriers shall be as specified in 260.75.20.

Part 2: Physical Requirements

260.75.10) Minimum Clearance of Live Parts (From Table 490–24 of the NEC).

Nominal Voltage Rating (kV)	Impulse Withstand B.I.L. (kV)	Minimum Clearance of Live Parts	
		Phase-to-Phase	Phase-to-Ground
		Indoors	Indoors
	Indoors	Inches	Inches
2.4–4.16	60	4.5	3.0
7.2	75	5.5	4.0
13.8	95	7.5	5.0
14.4	110	9.0	6.5
23	125	10.5	7.5
34.5	150	12.5	9.5
34.5	200	18.0	13.0

260.75.20) Minimum Clearances from Live Parts to Barriers.

System Class (kV)	Impulse Withstand B.I.L. (kV)	Minimum Phase-to-Barrier Clearance (Inches)
5	60	1.5
15	95	1.5
15	110	2.5
25	125	2.5
29 (26.4kV Nominal)	125	2.5
29 (26.4kV Nominal)	150	2.5
35	150	3.0
35	200	3.0

260.80) Momentary Current Rating

The integrated switchgear assembly (interrupter switches, breakers, power fuses, primary bus and enclosure) shall have a momentary current rating equal to or greater than the maximum available short circuit current at the point of application.

260.85) Protective Grounding

All compartments which contain incoming line terminations and/or service fuses shall be equipped with protective grounding facilities as described in Section 180.

260.90) Potheads and Other Cable Terminations

Adequate space shall be provided in the incoming line terminal compartments for the installation of potheads or other terminators (see Section 200.30 for additional detailed termination requirements).

Part 2: Physical Requirements

260.95) Accessibility to Outdoor Switchgear

Outdoor switchgear installations equipped with a weatherproof operating and maintenance aisle shall include provisions to secure at least one entrance door with two padlocks. Removal of either padlock shall be sufficient to gain entry. One of the two padlocks will be furnished and installed by We Energies. The second padlock shall be provided by the Customer.

Exception: When Customers provide We Energies keys to their padlock. These keys will be kept in key boxes furnished and installed by We Energies on the Customer's premises near the switchgear.

Part 2: Physical Requirements



270) Indoor Substations

270.10) General

270.10.10) Each aisle or work space about substation equipment shall have a suitable means of exit which shall be kept clear of all obstructions. If the plan of the vault and the character and arrangement of equipment are such that an accident would close or make inaccessible a single exit, a second exit shall be provided.

270.10.20) All personnel doors shall swing out and be equipped with full width panic bars that are normally latched but open under simple pressure for quick escape in the event of trouble. A description of the door latch shall be submitted to We Energies for approval. An example of an acceptable door latch is a Von Duprin catalog number 99NL-F

270.10.30) The customer shall furnish and install sufficient lighting fixtures to provide a minimum illumination intensity of 5 foot candles. If the room temperature is to be maintained above 40°F, fluorescent light fixtures may be used. The lighting fixtures shall be so arranged that persons changing lamps or making repairs on the lighting system will not be endangered by live parts or other equipment.

270.10.40) Only metal-enclosed equipment will be allowed in areas accessible to unqualified persons. This equipment must conform to the switchgear requirements listed in section 260. All other equipment must be located in an area where access to which is controlled by a lock.

270.10.50) The customer shall provide We Energies personnel 24-hour per day access to indoor vaults for the purpose of switching and maintenance.

270.20) Secondary Service Transformer Vaults.

270.20.05) Secondary Service Transformer Vaults requirements apply to a room in the customer's facility in which We Energies will build and own an electrical distribution substation. The customer is responsible for the structure and the environment and We Energies is responsible for the electrical distribution equipment.

270.20.10) Indoor vaults shall be located so as to be easily accessible by Company personnel to facilitate moving and operation of utility electrical distribution equipment. The customer must provide floors, doorways, passageways and/or elevators having structural strength and clearances adequate for the transportation, installation and replacement of transformers and associated equipment. These clearances should take into consideration the ultimate transformer size needed for the installation. It is highly desirable that a hatchway or doorway on an outside wall or ceiling of the vault will be provided such that the equipment can be installed directly from the outdoors.

Part 2: Physical Requirements

270.20.20) The size and shape of the vault in which We Energies equipment is to be installed must be sufficient to safely operate the installed equipment, perform maintenance on such equipment, and remove and replace such equipment should that become necessary. The vault size and shape will be specified by the We Energies Application Engineer.

270.20.30) The transformer vault shall be constructed according to the requirements of the Wisconsin State Administrative Code, Volume 1 and 2, “Electrical”, and meet the requirements of all local inspectors and local ordinances.

270.20.40) Vaults shall be located where they can be ventilated to the outside without using flues or ducts wherever such an arrangement is practicable. When special permission is granted by the administrative authority, flues and ducts may be used if the ducts are of a fire resistive construction.

270.20.50) The vault will be secured with a We Energies installed a high security cylinder lock in each door.

270.20.60) Pipe or duct systems foreign to the electrical installation shall not enter or pass through a transformer vault except by special permission. No system will be approved if it contains appurtenances that require maintenance.

270.20.70) Louvers at the outside of the building shall be covered with 8 mesh per inch copper wire screen and constructed to restrict entrance of snow and rain.

270.20.80) The walls and roofs of vaults shall be constructed of masonry materials which have adequate structural strength for the conditions with a minimum fire resistance of 3 hours. The floors of vaults in contact with earth shall be concrete not less than 4 inches thick, but when the vault is constructed with a vacant space or other rooms below it, the floor shall have adequate structural strength for the ultimate load and a minimum fire resistance of 3 hours.

270.20.90) The customer shall provide fireproof doors suitable for the required size of the doorway. All doors shall swing out of the vault. The We Energies Application Engineer will specify required doorway size and location. The fireproof rating of the door shall meet requirements of 270.20.80. A minimum 3.5” concrete sill or curb shall be provided under each vault doorway to contain within the vault the oil from the largest transformer unless the floor of the transformer vault is at least 4” inches below the adjacent area.

270.20.100) The customer shall provide floor drains to carry off any accumulation of water. The floor shall be pitched to the drains. Sump crocks and pumps associated with transformer vault floor drains shall be located outside of the transformer vault so they can be maintained without entry to the transformer vault. The customer shall consult with local sewerage district

Part 2: Physical Requirements

to determine what if any provisions are required to prevent transformer oil entry into the local sewer system in the event of a transformer case leak. The customer is responsible to install any required oil stop provisions.

270.20.110) The customer shall provide ventilation adequate to dispose of transformer full-load losses without creating an excessive ambient temperature (above 40°C).

a) For a vault ventilated by natural circulation, the combined net area of all ventilating openings shall not be less than 3 square inches per kVA of ultimate transformer capacity. Roughly half of the total area of openings required for ventilation shall be in one or more openings near the floor and the remainder in one or more openings in the roof or side walls near the roof. Intake and exhaust vents should be located at opposite ends of the vault to promote good air circulation.

b) For a vault ventilated by forced circulation, the forced air system shall provide a minimum ventilation capacity of 2 CF/M/kVA of ultimate transformer capacity. Fan or blower units shall be located outside of the transformer vault so that they can be maintained without entry to the transformer vault. Forced air systems shall be thermostat controlled with a turn-on temperature of 85° F.

270.20.120) When special permission is granted by the administrative authority to ventilate the transformer vault to the indoors, ventilation openings to the indoors shall be fitted with automatic closing fire dampers that operate in response to a vault fire. These dampers shall possess a standard fire rating of not less than 1-1/2 hours. For transformer vaults that are ventilated to the indoors the customer shall hold We Energies harmless for any damage that results from smoke or fire entry into the building associated with a transformer vault fire..

270.20.130) In addition to the lighting circuit, the customer is required to furnish and install one 20 ampere, 120 volt circuit in the transformer vault. This circuit shall be supplied from an emergency service, if present.

270.20.140) The customer shall provide fire suppression system (automatic sprinkler) if required by local inspectors and local ordinances. The fire suppression system shall be a type that is not damaged or activated by freezing temperatures. Heads and associated piping shall not obstruct replacement of transformers or switchgear.

270.20.150) Secondary services shall be metered per the We Energies “Electric Service and Metering Manual Book 1 and 2.

270.20.160) If the customer installs a We Energies approved service termination enclosure We Energies will extend secondary conductors within customer installed conduits from the

Part 2: Physical Requirements

transformer vault to the termination enclosure. We Energies will extend conductors no greater than 8 feet outside the transformer vault.

270.20.170) If the customer installs a termination enclosure that is not approved by We Energies, the customer must extend secondary conductors from the termination enclosure to the terminals of the We Energies owned transformers in the transformer vault.

270.20.180) The customer shall be responsible for all maintenance to the:

- a) Vault Structure – Walls, floors, ceiling, doors and fire proofing materials.
- b) Ventilation System – Louvers, screening, duct work, fans, motors, motor controllers, thermostats, etc.
- c) Drainage System – Drains, piping, sumps, pumps, etc.
- d) Lighting Systems – Bulbs, fixtures, switches, outlets, conduit and wire.
- e) Fire Suppression System – Sprinkler heads, piping, etc.

270.20.190) The Wisconsin State Administrative Code, Volume 2 “Electrical” and We Energies policy does not allow customers access to secondary metered substations. We Energies will inform the customer of any required maintenance, or at the request of the customer will escort the customer through the substation for the purpose of inspection. Any required maintenance will be performed by the customer or his contractor in the presence of a We Energies inspector.

270.30) Vault Agreement.

Prior to energizing any services from the transformer vault the customer shall sign a vault agreement stipulating to all items in section 270 above.

Part 2: Physical Requirements

280) Interlock Systems

280.10) General

280.10.10) Interlock systems are normally utilized to prevent:

- a) The unauthorized paralleling of two or more We Energies supply lines.
- b) Improper operation or sequence of operations of various pieces of substation equipment.
- c) Access to high voltage current carrying parts until such parts have been de-energized. All applicable codes shall be followed.

280.10.20) Interlock systems may be classified into three main divisions based on the type of interconnection between associated devices. The following is a brief description of each classification:

- a) Mechanical interlocks consist of a bar, chain, gear or other mechanical arrangement between associated devices.
- b) Electrical interlocks consist chiefly of switches and/or solenoids arranged at the associated devices and connected by electrical conductors. Application is limited to devices adjacent to a satisfactory electrical power source.
- c) Key interchange interlocks consist of self-contained individual locking units located at associated devices which permit a desired operation only when conditions are correct for that operation.

280.10.30) After the Customer has completed the initial installation of any We Energies required key-interchange interlock system, all keys (except those held captive in locks) are to be given to We Energies Start-Up Engineer for use in placing the substation equipment in operation. We Energies shall maintain possession and control over all such keys.

280.20) We Energies Required Interlocks for Specific Installations

The following list of We Energies required interlocks are for installations most frequently encountered in customer substations. We Energies may however require interlock systems for installations other than those specifically covered herein as they occur. Specific requirements for these special situations will be provided when necessary by We Energies.

Part 2: Physical Requirements

280.20.10) Two line supply with service circuit breakers – Single load fed from either source.

Customer shall provide and install an electrical or key interchange interlock system which will prevent paralleling of supply lines, and permit only one breaker to be closed at any one time by the customer. The system, however, shall permit both breakers to be open at the same time.

280.20.20) Two line supply with interrupter switches – Single load fed from either source.

Customer shall provide and install a key interchange interlock system for manually operated switches or a combination key interchange and electrical interlock system for motor-operated switches which will prevent paralleling of supply lines, by permitting only one interrupter switch to be closed at any one time by the customer. The interlock system shall, however, permit both interrupter switches to be open at the same time. See Part 3, Section II., E., Keyed Permissive Switches, for more information.

280.20.30) Two line supply with service circuit breakers – two loads fed from one source with one normally closed tie breaker or tie switch.

Customer shall provide and install a key interchange interlock system for manually operated devices or an electrical interlock system for electrically operated devices which will prevent paralleling of supply lines by permitting only two of the three devices to be closed at any one time by the customer. The interlock system shall, however, permit all three devices to be open at the same time.

280.20.40) Two line supply with interrupter switches – two loads fed from one source with one normally closed tie switch.

Customer shall provide and install a key interchange interlock system for manually operated switches or a combination electrical and key interchange interlock system for motor operated switches which will prevent paralleling of supply lines by permitting only two of the three interrupter switches to be closed at any one time by the customer. The interlock system shall, however, permit all three interrupter switches to be open at the same time.

Part 3: Equipment Control

300) Introduction

300.00.10) The design and construction of control circuits have a major effect upon the proper operation of the service circuit breakers and interrupter switches with which they are associated. We Energies has a vital interest in circuits which influence the ability of Customer-owned service equipment to perform switching and fault clearing functions. The design and construction of control circuits often receive less attention than the related power circuits, but a power system can operate only as effectively as permitted by its control circuits.

300.00.20) All control circuits for service circuit breakers and electrically operated interrupter switches shall be constructed in accordance with the requirements listed in following Section II. We Energies will specify the type, range, and settings of overcurrent relays and the associated current transformer ratios.

310) Control Circuit Practices

Circuit breakers or automatic switches should open for overcurrent conditions as specified by We Energies.

310.10) Control Circuit Relays

310.10.10) Standard device function numbers shall be assigned to identify the functions of all relays. Device function numbers may be found in American National Standard C37.2.

310.10.20) Relays shall be connected to provide proper operation and phasing for the intended application.

310.20) Control Circuits

A means shall be provided to disable the control package for purposes of securing a hold off position.

310.30) Bus Fault Detection

310.30.10) A bus fault detection system shall act to detect a fault and then open all incoming line switches or circuit breakers.

310.30.20) The alternate line switch or circuit breaker shall be blocked from closing after operation of bus fault detection system.

310.30.30) Bus fault protection requirements may vary with equipment insulation medium, construction, proximity of protective device, unprotected bus exposure, system application, interrupting duty, etc.

Part 3: Equipment Control

310.40) Instrument Transformer Connections

310.40.10) Each current or potential transformer secondary circuit shall have only one ground connection, constructed so that it can be conveniently removed without disturbing the circuit. The ground connection is to be located at the terminal block of the relay electrically nearest the instrument transformer.

310.40.20) All current transformer secondary circuit connections shall be made with copper #14 AWG gauge minimum stranded wire, containing no rotary switches, receptacles for test plugs, or tee joints. All connectors shall be of proven reliability.

310.40.30) All potential transformer secondary circuits shall be fused. Indicating lamps or alarm relays shall be provided to monitor all potential transformer secondary circuit fuses, unless the circuit contains relays which always cause a trip operation upon loss of voltage.

310.50) Keyed Permissive Switches

310.50.10) Customer substations energized by more than one supply line must be constructed so that the supply lines cannot normally be connected together through the substation bus. This is accomplished by wiring the control circuits for the line and bus tie circuit breakers or interrupter switches so that at least one circuit breaker or interrupter switch is open at all times. Provisions may be included, however, to permit We Energies only to close all of the circuit breakers or interrupter switches at the same time. This will enable We Energies to perform closed transition switching operations during abnormal power system conditions, and avoid the momentary service interruptions resulting from open transition switching.

310.50.20) A keyed permissive switch (Device 69) is recommended in all customer substations having more than one supply line. A contact of this switch is connected in the closing control circuit of each line and bus tie circuit breaker or interrupter switch. The keyed permissive switch for a substation with two supply lines shall have the following features:

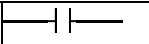
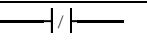
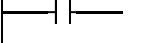
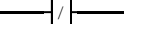
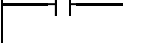
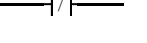
Switch Contact	Position 1	Position 2	Key Held Captive	
	Key Out	Key In and Turned	Position 1	Position 2
K1			No	Yes
K2			No	Yes
K3*			No	Yes

*Contact K3 need not be provided if a bus tie circuit breaker or an interrupter switch is not installed.

Part 3: Equipment Control

310.50.30) All keys for the device 69 keyed permissive switch must be given to the We Energies Start-Up Engineer after the Customer has proven to the Start-Up Engineer the operation of the circuit breaker or interrupter switch control circuits prior to placing the substation in service. All of the keys will be retained by We Energies

310.60) Miscellaneous Devices

Additional control circuit requirements are as follows:

310.60.10) All indicating lamps shall be color coded to indicate the functions of the lamps, as specified below:

Color	Function
Red	Close
Green	Open
Blue	Alarm
Orange	D-C Potential
White	A-C Potential
Clear	Ground Detection

310.60.20) All circuit breaker trip circuit fuses shall be monitored with indicating lamps or alarm relays.

320) Automatic Transfer Control for Switchgear and Circuit Breakers

The following are items pertain specifically to the installation and utilization of automatic transfer and control equipment. Any new control package must be carefully reviewed by We Energies to evaluate equipment integrity for the purpose of protecting the customer service reliability, and to protect the We Energies distribution system, minimizing disturbances to other customers. Additional requirements relative to supply conductor terminations, grounding provisions for supply conductors, service disconnected means, overcurrent protective devices, surge protection, interlock systems, and metering facilities are contained in Parts 1 and 2 of this book.

320.10) Position and Transfer

320.10.02) An open transition transfer scheme shall be incorporated into the control scheme to guarantee that during an automatic source transfer the incoming lines will not be tied together.

320.10.04) A loss-of-source voltage timer is necessary to delay source transfer and establish that the loss of source is not a transient condition. This will mitigate unnecessary switching. The loss-of-source (voltage) timers must be adjustable in a minimum 1–10 second range to allow for coordination with upstream We Energies protective devices.

Part 3: Equipment Control

320.10.10) Switch Operators and Breakers

- a) The switch operators or breakers must be provided with a method to mechanically (manually) operate, which is not dependent upon the control package electrical system.
- b) The switch operators or breakers must be a stored energy type so that one operation, either to open or to close can be done after loss of supply voltage.
- c) The switch operators or breakers must have targets to indicate its position (open/closed) and the operator status (charged/discharged and coupled/decoupled).

320.10.20) Switchgear Only Requirements

- a) Switch operators must have a provision for padlocking in both open and closed positions.
- b) The switch operator must be capable of being manually decoupled. The decoupled state must be visibly evident through some mechanically altered condition.
- c) The doors to the service switch bays and tie bay for live front equipment must be interlocked to the switch operators so that automatic and manual operation is blocked if any of the doors are open.
- d) It must not be possible to couple the operator to the switch if both are not in the same open/closed position, in such a manner that the position of either operator or switch indicates incorrectly.

320.10.30) Circuit Breaker Only Requirements

a) Two Lines Serving a Common Load with Automatic Transfer:

One set of overcurrent relays may be used for both lines' circuit breakers provided that the relays will not be affected during a time when We Energies may be performing closed transition switching as described above.

b) Two Lines Serving Separate Loads With Automatic Transfer:

- b.1)** This system may be operated with both line circuit breakers normally closed and the bus tie circuit breaker normally open, or with one line circuit breaker closed and the bus tie circuit breaker normally closed and the remaining line circuit breaker normally open.
- b.2)** The circuit breaker control circuits shall be arranged so that the three circuit breakers (two line breakers and one bus tie breaker) cannot be normally closed at the same time.

Part 3: Equipment Control

Keyed permissive switch contacts shall allow only We Energies to defeat this scheme to perform closed transition switching during abnormal power system conditions.

320.10.40) Preferred/Alternate Source Selection

- a) The control scheme must allow for field adaptation for selection of the preferred source.
- b) The control shall not allow the switchgear to automatically return to the preferred (normal) source after having been transferred to an alternate source. Source return shall be made only by We Energies personnel. The equipment may automatically return to the preferred supply if the alternate supply is de-energized and the preferred supply has been restored.

320.20) Indicating Features

Indicating lamps shall be provided to monitor both normal and alternate line potential conditions.

320.30) Sensing

320.30.10) If installed on the 26.4 kV subtransmission system, over/under voltage sensing must be adjustable to compensate for future conversion of primary voltage from 26.4 kV subtransmission to 24.9Y/14.4 kV distribution.

320.30.20) Potential transformers supplying control power or voltage sensing must have removable high and low voltages fuses. They must be We Energies approved devices since they are directly connected to We Energies lines.

330) Switchgear or Circuit Breaker with Manual Transfer

330.10) Two Lines Serving A Common Load With Manual Transfer

One set of overcurrent relays may be used for both lines' circuit breakers provided that the relays will not be affected during a time when We Energies may be performing closed transition switching during abnormal system configurations.

330.20) Two Lines Serving Separate Loads With Manual Transfer

330.20.10) This system may be operated with both line circuit breakers normally closed and the bus tie circuit breaker normally open, or with one line circuit breaker closed and the bus tie circuit breaker normally closed and the remaining line circuit breaker normally open.

Part 3: Equipment Control

330.20.20) The circuit breaker control circuits shall be arranged so that the three circuit breakers (two line breakers and one bus tie breaker) cannot be normally closed at the same time. Keyed permissive switch contacts shall allow only We Energies to defeat this scheme to perform closed transition switching during abnormal power system conditions.